



User Manual

ARK-1221L

Fanless Embedded Box Computer

ADVANTECH

Enabling an Intelligent Planet

Attention!

This product contains a hard copy of the Chinese user manual for China CCC certification purposes. A PDF of the English user manual is available online. Please disregard the hard copy of the Chinese user manual if the product is not sold and/or installed in China.

Copyright

The documentation and the software included with this product are copyrighted 2025 by Advantech Co., Ltd. All rights are reserved. Advantech Co., Ltd. reserves the right to make improvements in the products described in this manual at any time without notice.

No part of this manual may be reproduced, copied, translated or transmitted in any form or by any means without the prior written permission of Advantech Co., Ltd. Information provided in this manual is intended to be accurate and reliable. However, Advantech Co., Ltd. assumes no responsibility for its use, nor for any infringements of the rights of third parties, which may result from its use.

Acknowledgements

Award is a trademark of Award Software International, Inc.

VIA is a trademark of VIA Technologies, Inc.

IBM, PC/AT, PS/2, and VGA are trademarks of International Business Machines Corporation.

Intel® and Pentium® are trademarks of Intel® Corporation.

Microsoft Windows® is a registered trademark of Microsoft Corp.

RTL is a trademark of Realtek Semiconductor Co., Ltd.

ESS is a trademark of ESS Technology, Inc.

UMC is a trademark of United Microelectronics Corporation.

SMI is a trademark of Silicon Motion, Inc.

Creative is a trademark of Creative Technology, Ltd.

CHRONTEL is a trademark of Chrontel, Inc.

All other product names or trademarks are properties of their respective owners.

For more information about this or other Advantech products, visit our website at <http://www.advantech.com>

https://www.advantech.com/products/fanless-embedded-computers/sub_1-2jkeuf

For technical support and customer service, visit our support website at <http://support.advantech.com.tw/support>

Product Warranty (2 Years)

Advantech warrants to you, the original purchaser, that each of its products will be free from defects in materials and workmanship for two years from the date of purchase.

This warranty does not apply to any products which have been repaired or altered by persons other than repair personnel authorized by Advantech, or which have been subject to misuse, abuse, accident or improper installation. Advantech assumes no liability under the terms of this warranty as a consequence of such events.

Because of Advantech's high quality-control standards and rigorous testing, most of our customers never need to use our repair service. If an Advantech product is defective, it will be repaired or replaced at no charge during the warranty period. For out-of-warranty repairs, you will be billed according to the cost of replacement materials, service time, and freight. Please consult your dealer for more details.

If you think you have a defective product, follow these steps:

1. Collect all the information about the problem encountered. (For example, CPU speed, Advantech products used, other hardware and software used, etc.) Note anything abnormal and list any onscreen messages you get when the problem occurs.
2. Call your dealer and describe the problem. Please have your manual, product, and any helpful information readily available.
3. If your product is diagnosed as defective, obtain an RMA (return merchandise authorization) number from your dealer. This allows us to process your return more quickly.
4. Carefully pack the defective product, a fully-completed Repair and Replacement Order Card and a photocopy proof of purchase date (such as your sales receipt) in a shippable container. A product returned without proof of the purchase date is not eligible for warranty service.
5. Write the RMA number visibly on the outside of the package and ship it prepaid to your dealer.

Declaration of Conformity

FCC Class B

Note: This equipment has been tested and found to comply with the limits for a Class B digital device, pursuant to part 15 of the FCC Rules. These limits are designed to provide reasonable protection against harmful interference in a residential installation. This equipment generates, uses, and can radiate radio frequency energy and, if not installed and used in accordance with the instructions, may cause harmful interference to radio communications. However, there is no guarantee that interference will not occur in a particular installation. If this equipment does cause harmful interference to radio or television reception, which can be determined by turning the equipment off and on, the user is encouraged to try to correct the interference by one or more of the following measures:

- Reorient or relocate the receiving antenna.
- Increase the separation between the equipment and receiver.
- Connect the equipment to an outlet on a circuit different from that to which the receiver is connected.
- Consult the dealer or an experienced radio/TV technician for help.

Warnings, Cautions and Notes

Warning! *Warnings indicate conditions, which if not observed, can cause personal injury!*



Avertissement! *Les avertissements indiquent des conditions qui, si elles ne sont pas respectées, peuvent entraîner des blessure!*



Caution! *Cautions are included to help you avoid damaging hardware or losing data.*



Mise en garde! *Des précautions sont incluses pour vous aider à éviter d'endommager le matériel ou de perdre Les données.*



Note! *Notes provide optional additional information.*



Noter! *Les remarques fournissent des informations supplémentaires facultatives.*



Technical Support and Assistance

1. Visit the Advantech website at www.advantech.com/support where you can find the latest information about the product.
2. Contact your distributor, sales representative, or Advantech's customer service center for technical support if you need additional assistance. Please have the following information ready before you call:
 - Product name and serial number
 - Description of your peripheral attachments
 - Description of your software (operating system, version, application software, etc.)
 - A complete description of the problem
 - The exact wording of any error messages

Packing List

Before installation, check that the following items were included with the product:

- 1 x ARK-1221L unit
- 1 x 3-pin phoenix connector to DC-in
- 1 x 4-pin connector to switch
- 1 x DIN-rail bracket
- 1 x Simplified Chinese User Manual
- 1 x wrench for the top cover

Ordering Information

Model Number	Description
ARK-1221L-S5A1	Intel® Atom™ x6413E 1.5GHz w/ 2 x GbE and 2 x COM
ARK-1221L-S5A1U	Intel® Atom™ x6413E 1.5GHz w/ 2 x GbE and 2 x COM
ARK-1221L-S2A1	Intel® Celeron® N6210 1.5GHz w/ 2 x GbE and 2 x COM
ARK-1221L-U0A1	Intel® Celeron® J6412 2.0GHz w/ 2 x GbE and 2 x COM

Optional Accessories

Part Number	Description
96PSA-A60W24T2-3	AC to DC adapter, 24 V / 2.5 A 60 W
1702002600	Power cable 3-pin 183 cm (72 in), USA type
1702002605	Power cable 3-pin 183 cm (72 in), EU type
1700032693-11	Power cable 3-pin 183 cm (72 in), UK type
1700000237	Power cable 3-pin 183 cm (72 in), PSE type
AMK-W004	ARK-1220F wall mount kit (compatible with ARK-1221L)
1700023855-01	1M lockable HDMI cable
1700023856-01	3M lockable HDMI cable
1700030518-01	CAN bus cable

Safety Instructions

1. Read these safety instructions carefully.
2. Retain this user manual for future reference.
3. Disconnect the equipment from all power outlets before cleaning. Use only a damp cloth for cleaning. Do not use liquid or spray detergents.
4. For pluggable equipment, the power outlet socket must be located near the equipment and easily accessible.
5. Protect the equipment from humidity.
6. Place the equipment on a reliable surface during installation. Dropping or letting the equipment fall may cause damage.
7. Use a power cord connected to a socket-outlet with earthing connection.
8. Position the power cord away from high-traffic areas. Do not place anything over the power cord.
9. All cautions and warnings on the equipment should be noted.
10. If the equipment is not used for a long time, disconnect it from the power source to avoid damage from transient overvoltage.
11. Never pour liquid into an opening. This may cause fire or electrical shock.
12. Never open the equipment. For safety reasons, the equipment should be opened only by qualified service personnel.
13. If any of the following occurs, have the equipment checked by service personnel:
 - The power cord or plug is damaged.
 - Liquid has penetrated the equipment.
 - The equipment has been exposed to moisture.
 - The equipment is malfunctioning, or does not operate according to the user manual.
 - The equipment has been dropped and damaged.
 - The equipment shows obvious signs of breakage.
14. Do not leave the equipment in an environment with a storage temperature of below -40°C (-40°F) or above 85°C (185°F) as this may cause damage. The equipment should be stored in a controlled environment.
15. Any unverified components may cause unexpected damage. To ensure correct installation, always use the components (e.g., screws) provided in the accessory box.
16. **CAUTION:** The equipment is equipped with a battery-powered real-time clock circuit. There is a risk of explosion if a battery is incorrectly replaced. Replace only with the same or equivalent type as recommended by the manufacturer. Discard all used batteries according to the manufacturer's instructions.
17. Always disconnect the power cord from the chassis before manually handling the hardware. Do not implement connections or configuration changes while the device is powered on. Sudden power surges may damage sensitive electronic components.
18. In accordance with IEC 704-1:1982 specifications, the sound pressure level at the operator's position should not exceed 70 dB (A).
19. **DISCLAIMER:** These instructions are provided according to IEC 704-1 specifications. Advantech disclaims all responsibility for the accuracy of any statements contained herein.
20. The product is intended to be supplied by a UL listed power supply suitable for use at minimum T_{ma} of 60°C with output meeting PS2 (or PLS) and rated: 12-28 V_{DC}, 5-2.14 A min. with matching connector. If you need further assistance, please contact Advantech for more information.

21. **RESTRICTED ACCESS AREA:** The equipment should only be installed in a Restricted Access Area.

Consignes de sécurité

1. Veuillez lire attentivement ces instructions de sécurité.
2. Veuillez conserver ce manuel de l'utilisateur pour référence ultérieure.
3. Veuillez débrancher cet équipement de la prise secteur avant le nettoyage. Utilisez un chiffon humide. Ne pas utiliser de détergent liquide ou pulvérisé pour le nettoyage. Utilisez une feuille ou un chiffon humide pour le nettoyage.
4. Pour les équipements enfichables, la prise de courant doit être à proximité de l'équipement et doit être facilement accessible.
5. S'il vous plaît garder cet équipement de l'humidité.
6. Posez cet équipement sur une surface fiable lors de l'installation. Une chute ou une chute pourrait causer des blessures.
7. Au moyen d'un cordon d'alimentation connecté à une prise de courant avec mise à la terre.
8. Placez le cordon d'alimentation de sorte que personne ne puisse marcher dessus. Ne placez rien sur le cordon d'alimentation.
9. Tous les avertissements et mises en garde sur l'équipement doivent être notés.
10. Si l'appareil n'est pas utilisé pendant une longue période, débranchez-le du secteur pour ne pas être endommagé par une surtension transitoire.
11. Ne jamais verser de liquide dans les ouvertures de ventilation; Cela pourrait provoquer un incendie ou un choc électrique.
12. Ne jamais ouvrir l'équipement. Pour des raisons de sécurité, l'équipement ne doit être ouvert que par un personnel de service qualifié (par une personne qualifiée).
13. Si l'une des situations suivantes se présente, faites vérifier l'équipement par le personnel de service:
 - Le cordon d'alimentation ou la fiche est endommagé
 - Un liquide a pénétré dans l'appareil
 - L'équipement a été exposé à l'humidité
 - L'équipement ne fonctionne pas bien ou vous ne pouvez pas le faire fonctionner conformément au manuel d'utilisation
 - Equipment L'équipement est tombé et a été endommagé
 - Equipment L'équipement présente des signes évidents de rupture
14. Ne laissez pas cet équipement dans un environnement où la température de stockage peut être inférieure à -40°C (-40°F) ou supérieure à 85°C (185°F). Cela pourrait endommager l'équipement. L'équipement doit être dans un environnement contrôlé.
15. Tout composant non vérifié peut causer des dommages inattendus. Pour garantir une installation correcte, veuillez toujours utiliser les composants (ex. Vis) fournis avec la boîte d'accessoires.
16. **ATTENTION:** L'ordinateur est équipé d'un circuit d'horloge temps réel alimenté par batterie. Il y a un risque d'explosion si la batterie est remplacée de manière incorrecte. Remplacez uniquement avec le même type ou un type équivalent recommandé par le fabricant. Jetez les piles usagées conformément aux instructions du fabricant.
17. Débranchez toujours complètement le cordon d'alimentation de votre châssis lorsque vous utilisez du matériel. Ne faites pas de connexion quand l'appareil est sous tension. Les composants électroniques sensibles peuvent être endommagés par des surtensions soudaines.

18. Niveau de pression acoustique au poste de l'opérateur selon la norme CEI 704-1: 1982 n'est pas supérieur à 70 dB (A).
19. **AVERTISSEMENT:** Cet ensemble d'instructions est donné conformément à la norme CEI 704-1. Advantech décline toute responsabilité quant à l'exactitude des déclarations contenues dans ce.
20. Le produit est destiné à être alimenté par une alimentation homologuée UL convenant à une utilisation à T_{ma} minimum 60 degrés C dont la sortie est conforme à PS2 (ou PLS) et est évaluée: 12-28 V_{DC}, 5-2,14 A min. avec contre-connecteur. Si vous avez besoin d'aide supplémentaire, veuillez contacter Advantech pour plus d'informations.
21. **ZONE D'ACCÈS RESTREINT:** L'équipement ne doit être installé que dans une zone d'accès restreint.

Contents

Chapter 1 General Introduction1

1.1	Introduction	2
1.2	Product Specifications.....	2
	1.2.1 Processor System.....	2
	1.2.2 Memory.....	2
	1.2.3 Graphics.....	3
	1.2.4 Ethernet	3
	1.2.5 Audio.....	3
	1.2.6 I/O Interface	3
	1.2.7 Expansion	3
	1.2.8 Storage	3
	1.2.9 Other.....	3
	1.2.10 Software Support	3
	1.2.11 Power Requirements	3
	1.2.12 Power Consumption.....	3
	1.2.13 Mechanical.....	4
	1.2.14 Environment.....	4
1.3	Mechanical Drawing.....	5

Chapter 2 H/W Installation (Skilled Personnel) ..7

2.1	Introduction	8
2.2	Jumpers	8
	2.2.1 Jumper Description	8
	2.2.2 Jumper List	8
	Table 2.1: Jumper Settings.....	8
	2.2.3 Jumper Locations.....	9
	2.2.4 Jumper Settings.....	10
	Table 2.2: PSON1 (Main Board): AT/ATX Mode	10
	Table 2.3: JCMOS1 (Main Board): Clear CMOS.....	10
	Table 2.4: CN18 (Main Board): M.2 B-Key Interface Selection .	10
	Table 2.5: CN20 (Main Board): M.2 B-Key Power Selection.....	10
	Table 2.6: ERP1 (Main Board): Power Saving for ERP.....	11
	Table 2.7: J1 (I/O Board): COM1 RS232/422/485 Mode Selection	11
	Table 2.8: J2 (I/O Board): COM1 Termination.....	11
	Table 2.9: J4 (I/O Board): COM2 RS232/422/485 Mode Selection	11
	Table 2.10: J5 (I/O Board): COM2 Termination.....	12
	Table 2.11: SW1 (I/O Board): RS-485/RS-422 Failsafe	12
	Table 2.12: SW3 (I/O Board): RS-485/RS-422 Failsafe	12
2.3	System I/O	13
2.4	External I/O	14
	2.4.1 Power On/Off Button.....	14
	Figure 2.1 Power On/Off Button	14
	2.4.2 Power Input Connector	14
	Figure 2.2 Power Input Connector.....	14
	2.4.3 Ethernet Connector (LAN)	14
	Figure 2.3 Ethernet Connector (LAN).....	14
	Table 2.13: Ethernet Connector (LAN) PIN Definitions	14
	2.4.4 USB 3.2 Connector.....	15
	Figure 2.4 USB 3.2 Connector.....	15
	Table 2.14: USB 3.2 PIN Definitions	15
	2.4.5 USB 2.0 Connector.....	15

	Figure 2.5 USB 2.0 Connector	15
	Table 2.15: USB 2.0 PIN Definitions	15
2.4.6	Audio Connector	16
	Figure 2.6 Audio Connector	16
2.4.7	COM Connector	16
	Figure 2.7 COM Connector	16
	Table 2.16: COM Connector PIN Definitions	16
2.4.8	HDMI Connector	17
	Figure 2.8 HDMI Connector	17
	Table 2.17: HDMI Connector PIN Definitions	17
2.4.9	DP Connector	17
	Figure 2.9 DP Connector	17
	Table 2.18: DP Connector PIN Definitions	18
2.4.10	DIO Connector	18
	Figure 2.10 DIO Connector	18
	Table 2.19: DIO Connector PIN Definitions	18
2.4.11	Remote Switch Connector	19
	Figure 2.11 Remote Switch Connector	19
	Table 2.20: Remote Switch Connector PIN Definitions	19
2.5	Installation	20
2.5.1	2.5" HDD/SSD Installation	20
2.5.2	Memory Installation	21
2.5.3	mPCIe/mSATA Installation	22
2.5.4	M.2 Installation	23
2.5.5	Optional Adapter Installation	24
2.5.6	Wall Mount Installation	25
2.5.7	DIN-Rail Mount Installation	25
2.5.8	Optional CAN Bus Cable Installation	26

Chapter 3 BIOS Settings 29

3.1	Introduction	30
3.2	Entering BIOS Setup	30
3.2.1	Main Setup	30
3.2.2	Advanced Setup	31
3.2.3	Chipset	57
3.2.4	Security	71
3.2.5	Boot	73
3.2.6	Save & Exit	74

Chapter 1

General Introduction

This chapter details background information on the ARK-1221L series.

1.1 Introduction

The ARK-1221L is a compact, fanless DIN-rail embedded system that features an Intel® Atom™ x6413E quad-core processor and essential I/O on the front bezel for easy access and installation.

Rugged Design with Compact Dimensions

The ARK-1221L is equipped with a dual-channel memory slot that supports up to 32 GB of DDR4 3200 MHz SODIMM. Built for harsh industrial environments, the ruggedized system supports a wide operating temperature (-40 ~ 60°C / -40 ~ 140°F) and wide input power range (12 ~ 28 V_{DC}).

Its I/O options include:

- 2 x USB 2.0
- 2 x USB 3.2
- 2 x RS232/422/485 ports
- 2 x LAN ports (10/100/1000/2500 Mbps)
- 1 x Mic-In/Line-Out
- 1 x HDMI
- 1 x DisplayPort (DP)

The system also comes with expansion options including:

- 1 x full-size Mini PCIe
- 1 x M.2 2230 E-Key
- 1 x M.2 2280 B-Key
- Support for a 2.5" SSD

Thanks to its compact size, the ARK-1221L is ideal for installations where space is limited.

Built-In Intelligent Management Tools – WISE DeviceOn

Advantech's WISE DeviceOn platform, integrated with McAfee and Acronis, provides a powerful suite of programmable APIs, such as a multi-level watchdog, hardware monitor, system restore, and other user-friendly interfaces. With the inclusion of WISE DeviceOn, the ARK-1221L can be used for remotely managing, monitoring, configuring, and controlling numerous terminals to ensure easy maintenance and recovery.

1.2 Product Specifications

1.2.1 Processor System

- **CPU:** Intel® Atom™ x6413E Quad-Core SoC / Intel® Celeron® N6210 Dual Core SoC / Intel® Celeron® J6412 Quad-Core SoC
- **Frequency:** 1.50 GHz / 1.2 GHz / 2.0 GHz
- **Number of Cores:** 4 / 2 / 4
- **BIOS:** AMI EFI 256 Mbit

1.2.2 Memory

- **Technology:** DDR4 3200 MHz

- **Max Capacity:** 32 GB
- **Socket:** 2 x 260-pin SODIMM, 2 x 16 GB, or 1 x 32 GB memory

1.2.3 Graphics

- **Chipset:** Intel® UHD Graphics for 10th Gen Intel® Processors
- **HDMI:** Up to 4096 x 2160 @ 30 Hz
- **DP:** Up to 4096 x 2160 @ 60 Hz
- **Dual Display:** HDMI + DP

1.2.4 Ethernet

- **LAN1:** Intel® i225-LM, 2.5 GbE, supports Wake-on-LAN
- **LAN2:** Intel® i225-LM, 2.5 GbE, supports Wake-on-LAN

1.2.5 Audio

- **Interface:** Realtek ALC888S, High Definition Audio, Mic-In, Line-Out

1.2.6 I/O Interface

- **Serial Ports:** 2 x RS-232/422/485 (default RS-232) with auto flow control
- **USB Ports:** 2 x USB 3.2, 2 x USB 2.0, 1 x internal USB 2.0 for security dongle
- **GPIO:** 8-bit programmable DIO
- **Optional CAN bus:** 1 x CAN bus 2.0 (DB9 connector)

1.2.7 Expansion

- **Mini PCIe:** 1 x full-size mPCIe
- **M.2:** 1 x M.2 2230 E-Key and 1 x M.2 2280 B-Key with nano SIM holder #1

1.2.8 Storage

- **SSD/HDD:** 1 x 2.5" SATA III drive bay (compatible with 9 mm height)
- **mSATA:** 1 x full-size mSATA (*shared with the mPCIe slot)

1.2.9 Other

- **Watchdog Timer:** 255-level timer interval, set up through software
- **TPM:** TPM 2.0 (project supported by AMO-I029)

1.2.10 Software Support

- **Microsoft Windows:** Windows 10/11 Enterprise
- **Linux:** Ubuntu 20.4

1.2.11 Power Requirements

- **Power Type:** ATX/AT
- **Power Input Voltage:** 12-28 V_{DC}
- **Power Adapter:** AC to DC, 24 V / 2.5 A, 60 W (optional)

1.2.12 Power Consumption

- **Typical:** 9.6 W/12.66W/12.97W (x6413E/N6210/J6412) (OS idle mode)
- **Max.:** 18.96 W/21.89W/26.46W (x6413E/N6210/J6412) (full loading)

1.2.13 Mechanical

- **Construction:** Aluminum housing
- **Mounting:** DIN-rail / wall mount (optional)
- **Dimensions (W x H x D):** 60 x 158 x 114 mm (2.34" x 6.22" x 4.49")
- **Weight:** 1.05 kg (2.31 lb)

1.2.14 Environment

- **Operating Temperature*:**
 - Atom® x6413E: With extended temp. peripherals: -40 ~ 60°C (-40 ~140°F) with 0.7 m/s air flow (only up to 40°C when used with the adapter)
 - Celeron® N6210/ Celeron® J6412: With extended temp. peripherals: -20 ~ 60°C (-4 ~140°F) with 0.7 m/s air flow (only up to 40°C when used with the adapter)
- **Storage Temperature:** -40 ~ 85°C (-40 ~ 185°F)
- **Relative Humidity:** 95% @ 40°C (non-condensing)
- **Vibration during Operation:** With SSD: 3 Grms, IEC60068-2-64, random, 5~500 Hz, 1hr/axis (with wall mount)
- **Shock during Operation:** With SSD: 30 G, IEC-60068-2-27, half sine, 11 ms duration (with wall mount)
- **EMC:** CE/FCC Class B, CCC, BSMI
- **Safety:** UL, CB, CCC and BSMI

*for SKU with CPU x6413E only

1.3 Mechanical Drawing

Unit: mm

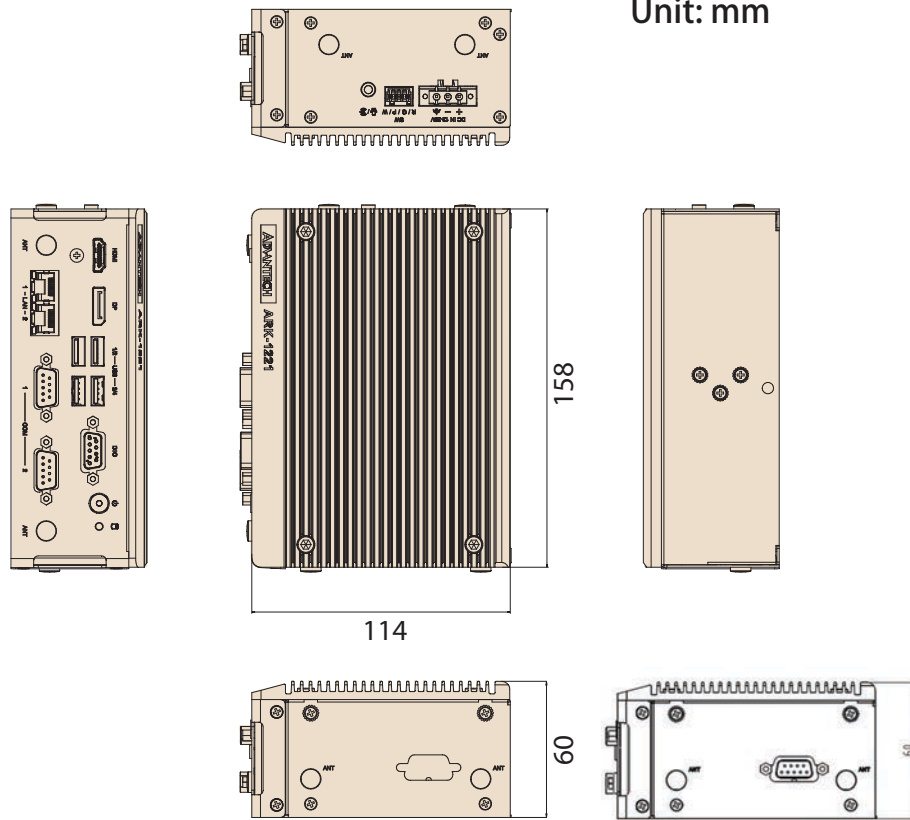

Wall Mount

DIN Rail

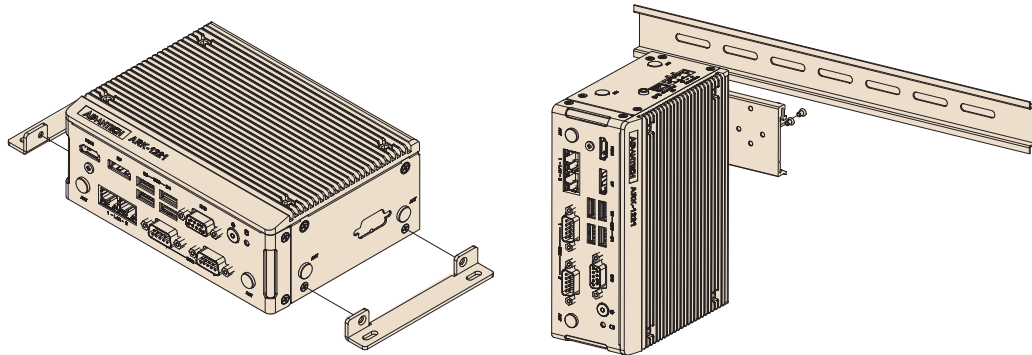

Chapter 2

H/W Installation (Skilled Personnel)

This chapter details instructions for installing the ARK-1221L series.

- **Note:** The hardware installation must be performed by skilled personnel.

2.1 Introduction

The following sections show the internal jumper settings and the external connector pin assignments.

2.2 Jumpers

2.2.1 Jumper Description

The ARK-1221L can be configured to satisfy specific application requirements by setting jumpers. A jumper is a metal bridge used to close an electric circuit. It consists of two metal pins and a small metal clip (often protected by a plastic cover) that slides over the pins to connect them. To close a jumper, connect the pins with the clip. To open a jumper, remove the clip. Sometimes a jumper will have three pins – labeled 1, 2, and 3. For these jumpers, connect either pins 1 and 2, or 2 and 3.

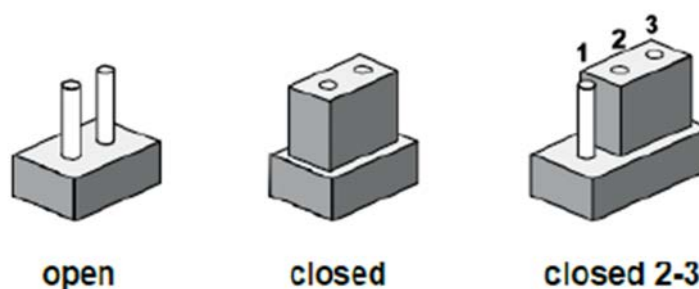

The jumper settings are schematically depicted as follows.

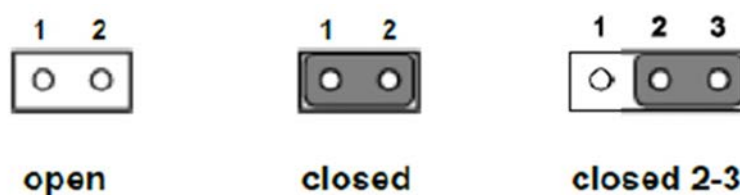

A pair of needle-nose pliers may be necessary when working with jumpers. Users with concerns about the ideal hardware configuration for their application should contact their local distributor or sales representative before making any changes. Generally, only a standard cable is required to make connections.

2.2.2 Jumper List

Table 2.1: Jumper Settings

Location	Function
PSON1 (main board)	AT/ATX Mode
JCMOS1 (main board)	Clear CMOS
CN18 (main board)	M.2 B-Key interface selection
CN20 (main board)	M.2 B-Key power selection
ERP1(main board)	Power saving for ERP
J1 (I/O board)	COM1 RS232/422/485 mode selection
J2 (I/O board)	COM1 Termination
J4 (I/O board)	COM2 RS232/422/485 mode selection
J5 (I/O board)	COM2 Termination
SW1, SW3 (I/O board)	RS-485/RS422 failsafe for COM1, COM2

2.2.3 Jumper Locations

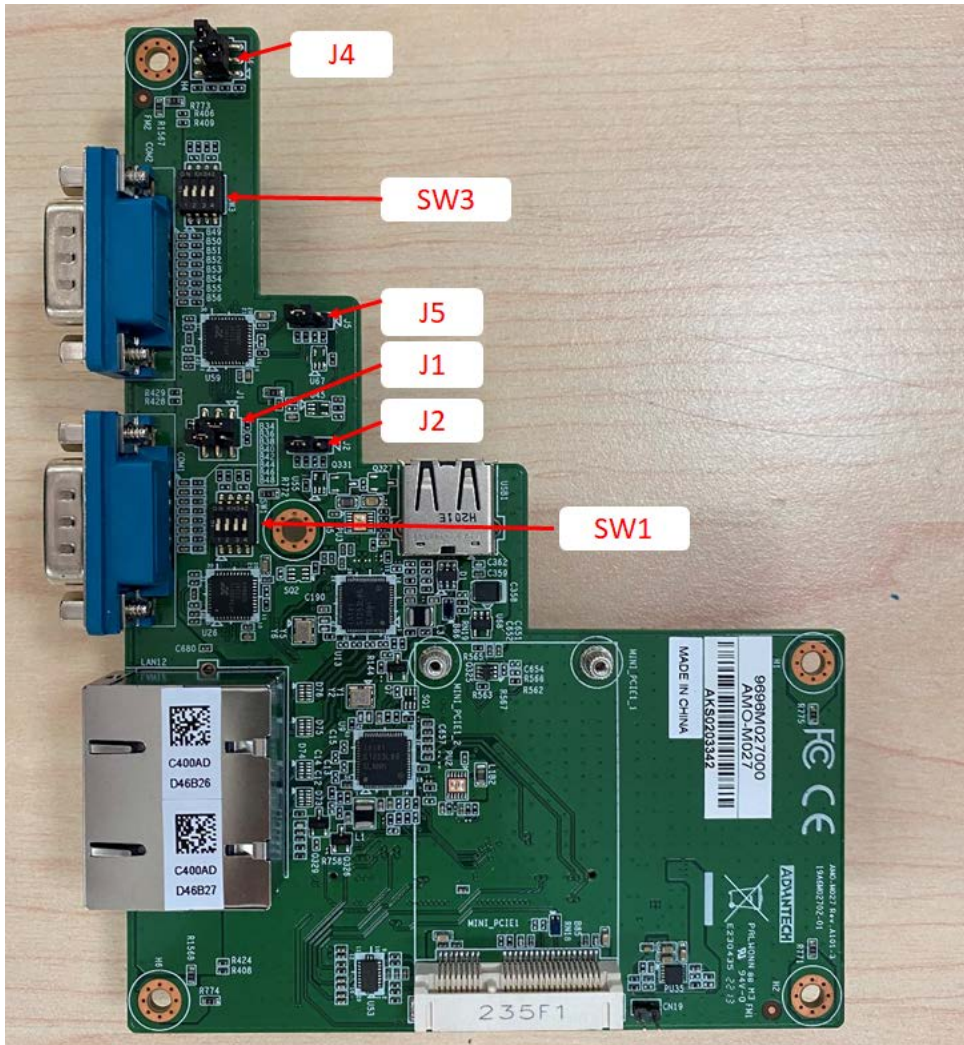
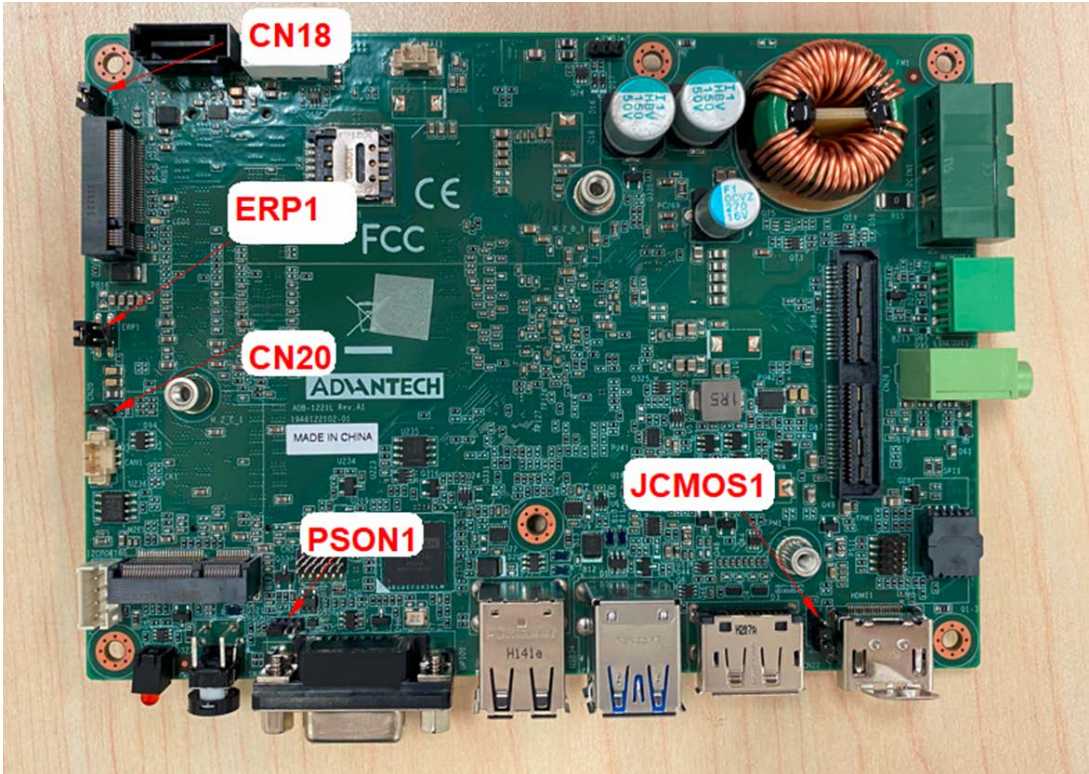

2.2.4 Jumper Settings

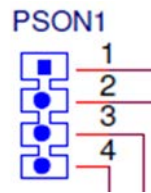

Table 2.2: PSON1 (Main Board): AT/ATX Mode

PIN	Description
1-2	ATX Mode (default)
3-4	AT Mode

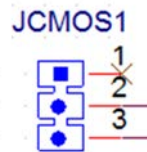

Table 2.3: JCMOS1 (Main Board): Clear CMOS

PIN	Description
1-2	Normal operation (default)
2-3	Clear CMOS

Note! JCMOS1 should only be accessed by skilled personnel.

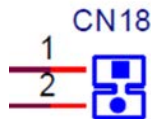

Table 2.4: CN18 (Main Board): M.2 B-Key Interface Selection

PIN	Description
1-2 Short	PCIe (default)
1-2 NC	USB 3.2 Gen1

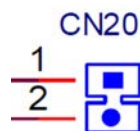
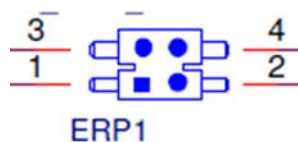
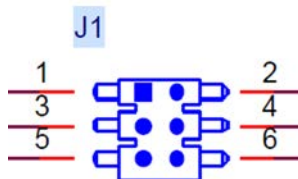

Table 2.5: CN20 (Main Board): M.2 B-Key Power Selection

PIN	Description
1-2 short	M.2 B-Key VCC = 3.8 V
1-2 NC	M.2 B-Key VCC = 3.3 V (default)
Jumper cap part number 1653008397-01	

Table 2.6: ERP1 (Main Board): Power Saving for ERP

PIN	Description
1-2	ERP Disable (default)
3-4	ERP Enable

Table 2.7: J1 (I/O Board): COM1 RS232/422/485 Mode Selection

PIN	Description
1-3 short 4-6 short	RS232 mode (default)
3-5 short 2-4 short	RS485 mode
1-3 short 2-4 short	RS422 mode

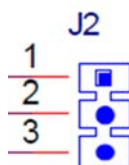
Table 2.8: J2 (I/O Board): COM1 Termination

Pin	Description
1-2 short	Enable
2-3 short	Disable (default)

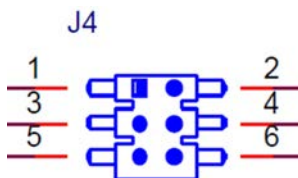
Table 2.9: J4 (I/O Board): COM2 RS232/422/485 Mode Selection

PIN	Description
1-3 short 4-6 short	RS232 mode (default)
3-5 short 2-4 short	RS485 mode
1-3 short 2-4 short	RS422 mode

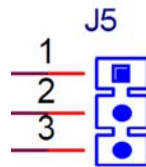

Table 2.10: J5 (I/O Board): COM2 Termination

Pin	Description
1-2 short	Enable
2-3 short	Disable (default)

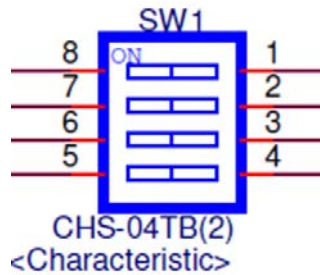

Table 2.11: SW1 (I/O Board): RS-485/RS-422 Failsafe

Pin	Description
1-8, 2-7, 3-6, 4-5 On	Enable COM1 failsafe
1-8, 2-7, 3-6, 4-5 Off	Disable COM1 failsafe (default)

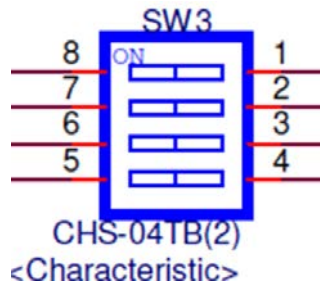
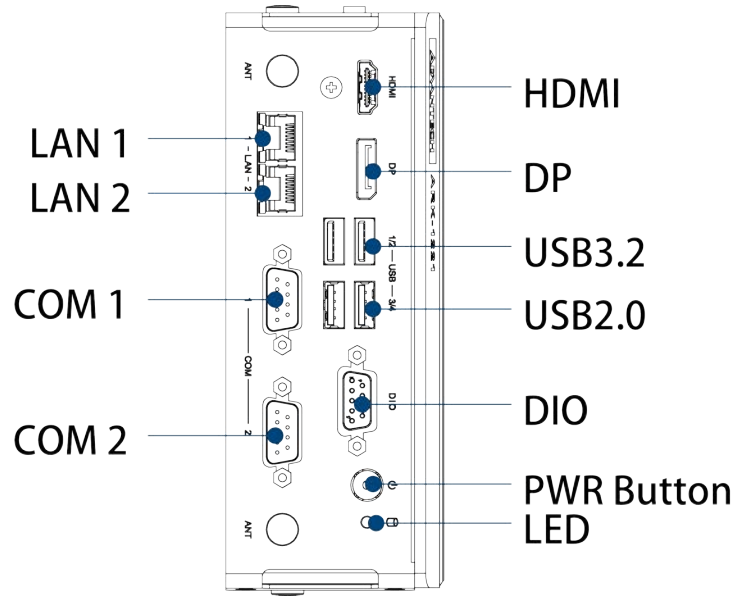

Table 2.12: SW3 (I/O Board): RS-485/RS-422 Failsafe

Pin	Description
1-8, 2-7, 3-6, 4-5 On	Enable COM2 failsafe
1-8, 2-7, 3-6, 4-5 Off	Disable COM2 failsafe (default)

2.3 System I/O

Front Panel External I/O Mechanical Layout/Drawing



Top Panel External I/O Mechanical Layout/Drawing

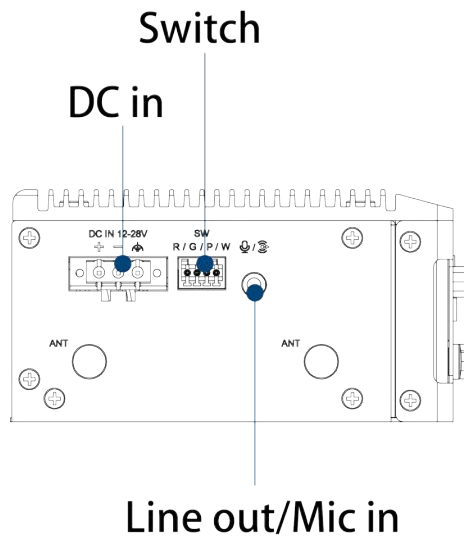

Bottom Panel External I/O Mechanical Layout/Drawing

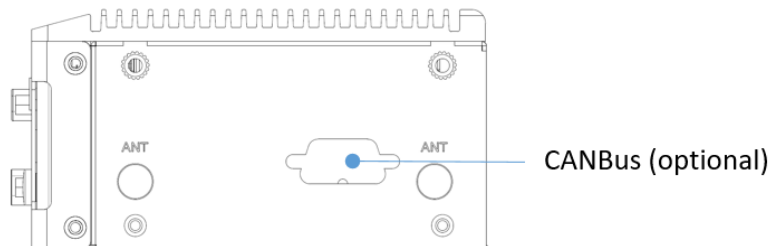

2.4 External I/O

2.4.1 Power On/Off Button

The ARK-1221L features a Power on/off button with an LED indicator on top that shows On status (Green LED).



Figure 2.1 Power On/Off Button

2.4.2 Power Input Connector

The power input connector supports 12-28 V. The 3 pins are defined as +, -, and GND.

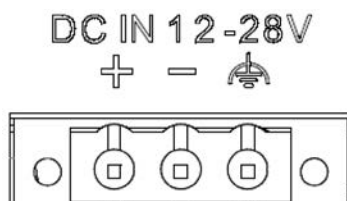

Figure 2.2 Power Input Connector

2.4.3 Ethernet Connector (LAN)

The ARK-1221L is equipped with two Intel® i225-LM Ethernet controllers connected to LAN1 and LAN2. The Ethernet ports provide standard RJ-45 jack connectors with LED indicators on the sides to show Active/Link status (Green LED) and speed status (Yellow LED).

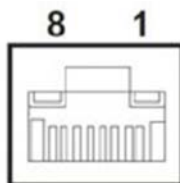

Figure 2.3 Ethernet Connector (LAN)

Table 2.13: Ethernet Connector (LAN) PIN Definitions

Pin	10/100/1000/2500 Mbps Signal Name
1	BI_DA+(GHz)
2	BI_DA+(GHz)
3	BI_DB+(GHz)
4	BI_DC+(GHz)
5	BI_DC-(GHz)
6	BI_DB-(GHz)
7	BI_DD+(GHz)
8	BI_DD-(GHz)
H3	GND
H4	GND

2.4.4 USB 3.2 Connector

The ARK-1221L supports two USB 3.2 interfaces which support plug-and-play functionality and hot swapping. The USB interfaces comply with USB UHCI, Rev. 3.0.



Figure 2.4 USB 3.2 Connector

Table 2.14: USB 3.2 PIN Definitions	
Pin	Signal Name
1	+5V
2	D-_0
3	D+_0
4	GND
5	USB0_SSRX-
6	USB0_SSRX+
7	GND
8	USB0_SSTX-
9	USB0_SSTX+

2.4.5 USB 2.0 Connector

The ARK-1221L provides two USB 2.0 interface connectors. The USB interface supports plug-and-play functionality.

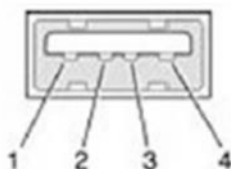

Figure 2.5 USB 2.0 Connector

Table 2.15: USB 2.0 PIN Definitions	
Pin	Signal Name
1	VCC
2	USB_data-
3	USB_data+
4	GND

2.4.6 Audio Connector

The ARK-1221L features one phone jack connector that supports a stereo Line-Out or Mic-In audio port. The audio chip is controlled by ALC888S and compliant with Azalea standards.



Figure 2.6 Audio Connector

2.4.7 COM Connector

The ARK-1221L provides two 9-pin COM connectors, which support RS-232/422/485 serial communication interface ports. The default setting is RS-232; if you want to use RS-422/485, you can change the jumper setting.

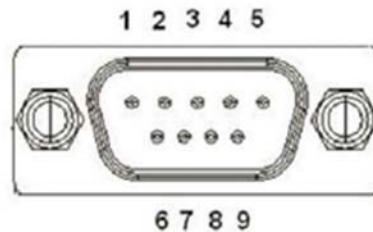

Figure 2.7 COM Connector

Table 2.16: COM Connector PIN Definitions

Pin	RS-232	RS-422	RS-485
1	DCD	Tx-	DATA-
2	RxD	Tx+	DATA+
3	TxD	Rx+	NC
4	DTR	Rx-	NC
5	GND	GND	GND
6	DSR	NC	NC
7	RTS	NC	NC
8	CTS	NC	NC
9	RI	NC	NC

NC represents "No Connection"

2.4.8 HDMI Connector

The ARK-1221L offers one integrated 19-pin receptacle connector HDMI 1.4b interface. The HDMI link supports resolutions up to 4096 x 2160 @ 30 Hz.

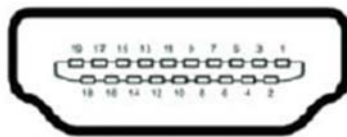

Figure 2.8 HDMI Connector

Table 2.17: HDMI Connector PIN Definitions

Pin	Signal Name
1	HDMI_TX2+
2	GND
3	HDMI_TX2-
4	HDMI_TX1+
5	GND
6	HDMI_TX1-
7	HDMI_TX0+
8	GND
9	HDMI_TX0-
10	HDMI_CLK+
11	GND
12	HDMI_CLK-
13	NC
14	NC
15	HDMI_DCLK
16	HDMI_DDAT
17	GND
18	+V5_HDMI-HPD
19	DDP0_HPDP

NC represents "No Connection"

2.4.9 DP Connector

ARK-1221L offers one 20-pin DP connector. It supports resolutions up to 4096 x 2160 @ 60 Hz.

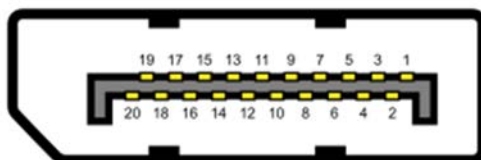

Figure 2.9 DP Connector

Table 2.18: DP Connector PIN Definitions

Pin	Signal Name
1	ML_Lane 0 (p)
2	GND
3	ML_Lane 0 (n)
4	ML_Lane 1 (p)
5	GND
6	ML_Lane 1 (n)
7	ML_Lane 2 (p)
8	GND
9	ML_Lane 2 (n)
10	ML_Lane 3 (p)
11	GND
12	ML_Lane 3 (n)
13	CONFIG1
14	CONFIG2
15	AUX CH (p)
16	GND
17	AUX CH (n)
18	Hot plug
19	GND
20	DP_PWR

2.4.10 DIO Connector

The ARK-1221L provides one 8-bit DIO connector.

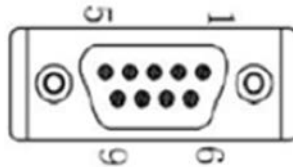
**Figure 2.10 DIO Connector****Table 2.19: DIO Connector PIN Definitions**

Pin	Signal Name
1	DIO bit 0
2	DIO bit 1
3	DIO bit 2
4	DIO bit 3
5	DIO bit 4
6	DIO bit 5
7	DIO bit 6
8	DIO bit 7
9	GND

2.4.11 Remote Switch Connector

The ARK-1221L provides a remote switch connector for power on/off via an external cable.

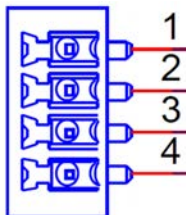

Figure 2.11 Remote Switch Connector

Table 2.20: Remote Switch Connector PIN Definitions

Pin	Signal Name
1	RESET BTN
2	GND
3	PWR BTN
4	WDT

2.5 Installation

Note! This should be performed by skilled personnel.



2.5.1 2.5" HDD/SSD Installation

Note! A 2.5" HDD/SSD cannot be installed together with a 5G module on the M.2 B-Key.



1. Loosen the 4 screws (2 on the left side and 2 on the right) and remove the bottom cover.

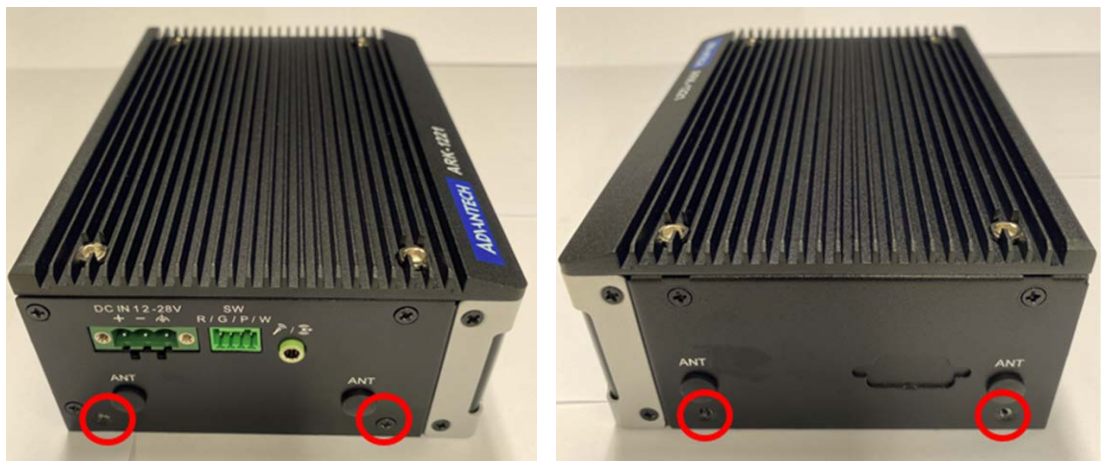

2. Attach the 2.5" SATA HDD/SSD to the bottom cover with four screws and connect one end of the SATA cable to HDD/SSD.



3. Put the bottom cover back and secure it with the 4 screws.

2.5.2 Memory Installation

1. Remove the top cover with the wrench in the accessory box.



2. Install RAM into the slots.

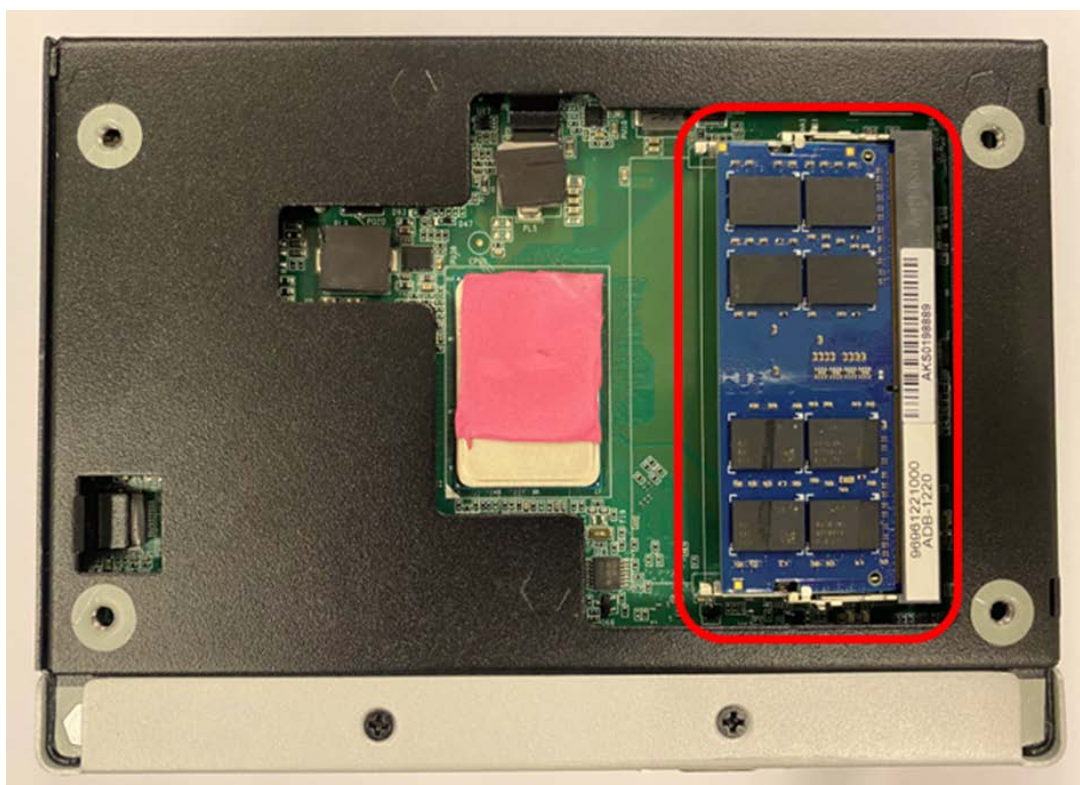

3. Put the top cover back and secure it with the 4 screws.

2.5.3 mPCIe/mSATA Installation

1. Loosen the 4 screws and remove the bottom cover.

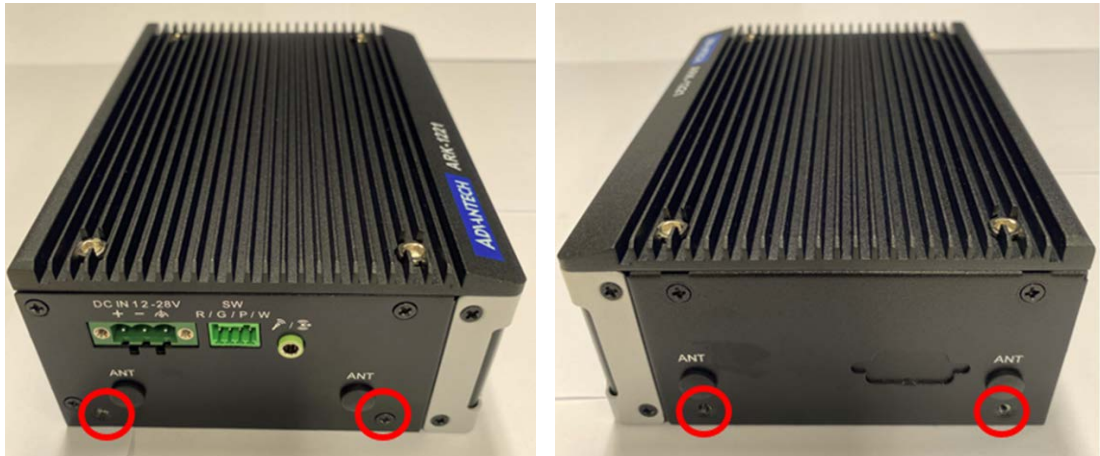

2. Install the mPCIe/mSATA module.

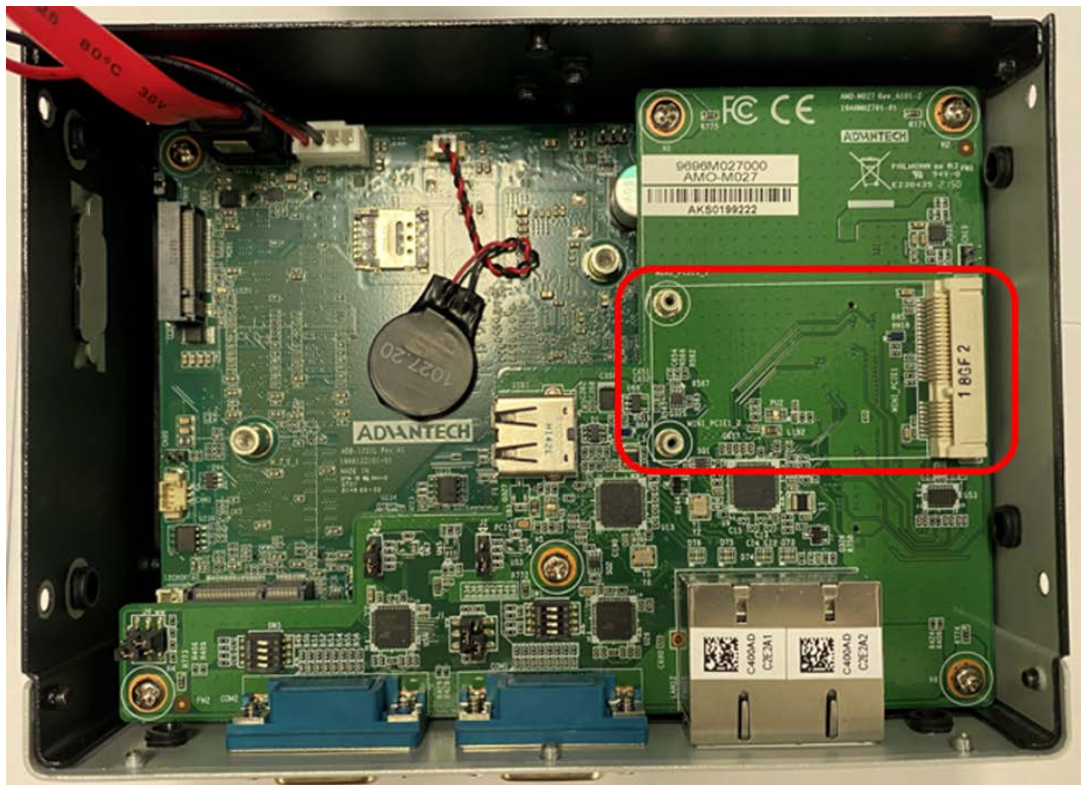

3. Put the bottom cover back and secure it with the 4 screws.

2.5.4 M.2 Installation

1. Loosen the 4 screws and remove the bottom cover.

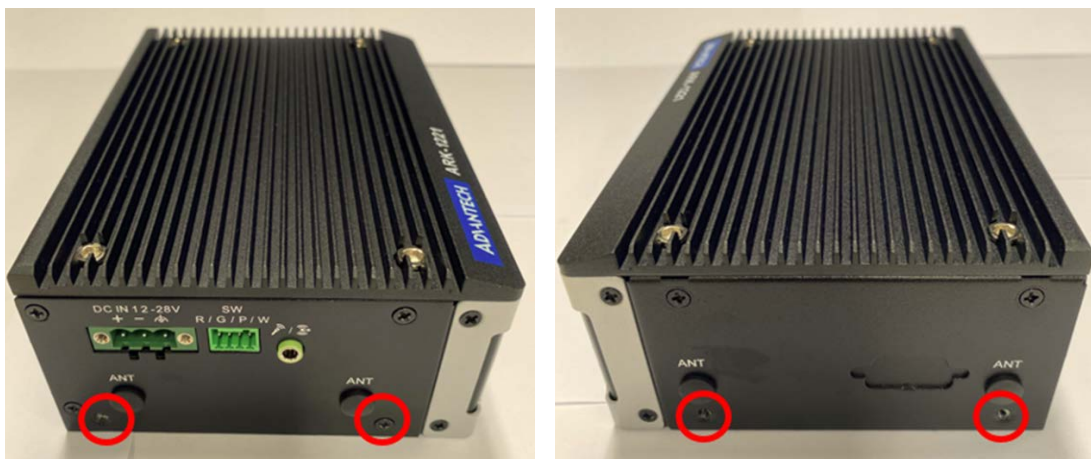

2. Install the M.2 E-Key module.
3. Install the M.2 B-Key module.

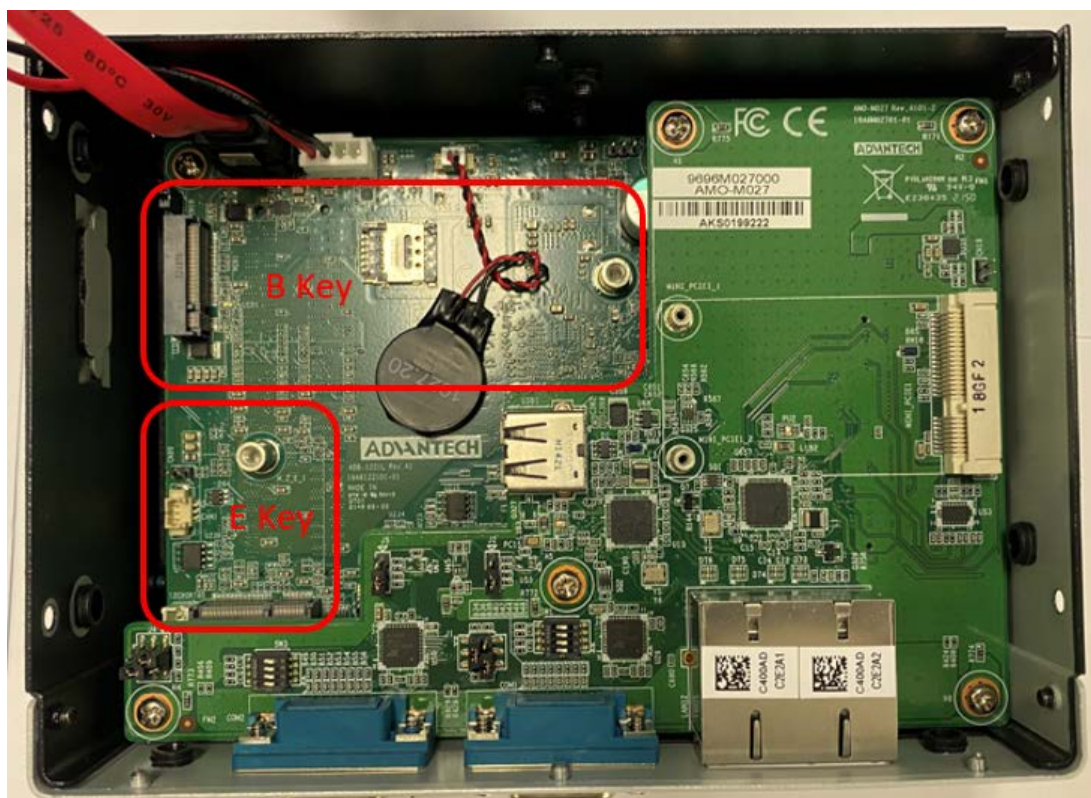

4. Put the bottom cover back and secure it with the 4 screws.

Note! An extra thermal solution may be required for certain modules installed on the M.2 interface.



2.5.5 Optional Adapter Installation

1. Connect the 3-pin phoenix connector to the DC input.



2.5.6 Wall Mount Installation

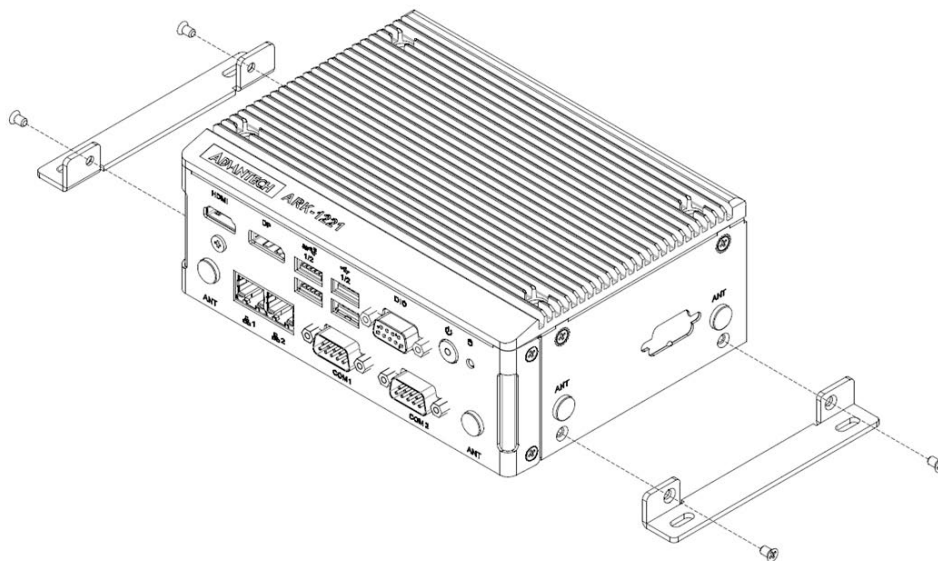

1. Unscrew the four M3x5L screws on both sides of the ARK-1221L.
 2. Secure the wall mount brackets on both sides of the ARK-1221L using the four screws removed in the above step.
1. Dévissez les quatre vis (M3x5L) des deux côtés de l'ARK-1221L.
 2. Vissez les supports de montage mural des deux côtés de l'ARK-1221L avec les quatre vis à l'arrière.

2.5.7 DIN-Rail Mount Installation

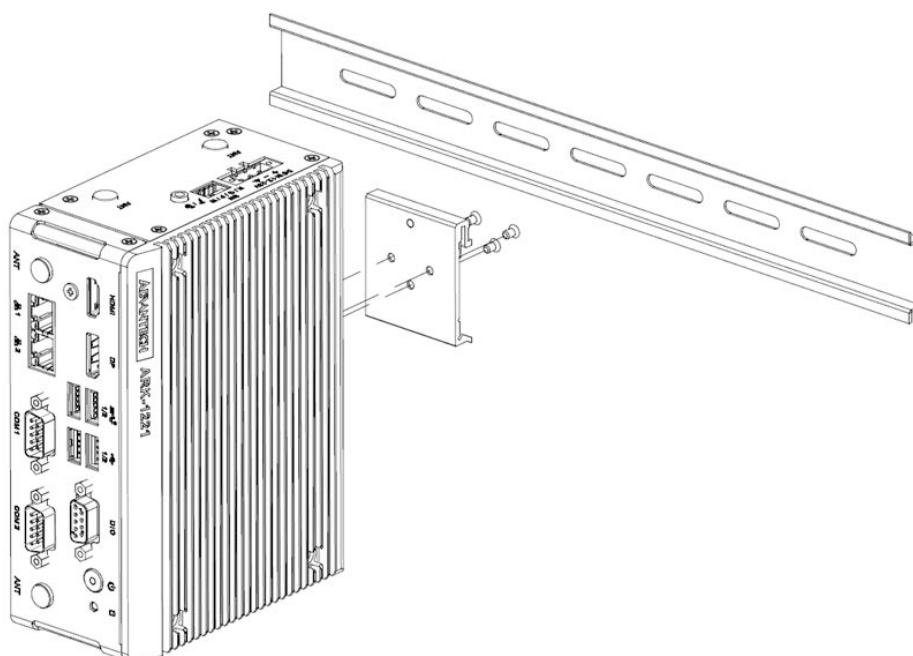

1. Unscrew the 3 x M3x5L screws from the back side of the ARK-1221L.
 2. Secure the DIN-rail bracket using three screws on the back.
1. Dévissez les trois vis (M3x5L) à l'arrière de l'ARK-1221L.
 2. Revissez le support du rail DIN avec les trois vis.

2.5.8 Optional CAN Bus Cable Installation

1. Loosen the 4 screws and remove the bottom cover.

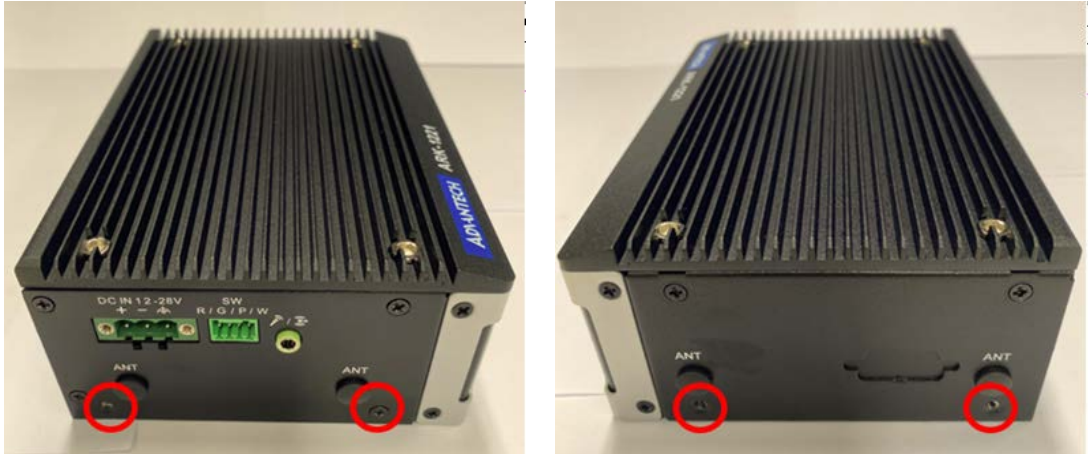

2. Install the CAN bus cable and fix the connector on the side of the cabinet.

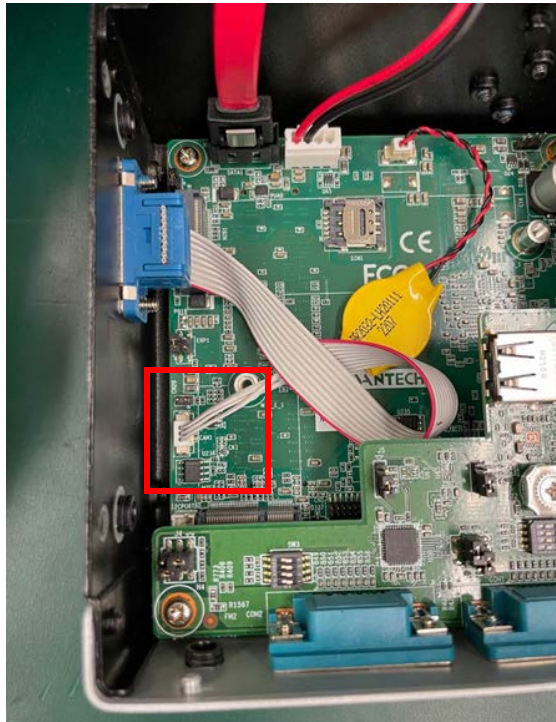

3. Put the bottom cover back and secure it with the 4 screws.

4. CANbus cable connector pin definitions are shown below.

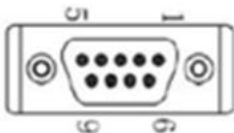

Pin	Signal Name
1	NC
2	CAN_L
3	GND
4	NC
5	NC
6	NC
7	CAN_H
8	NC
9	NC

Note! Please update BIOS with Advantech part number "1420056720" if installing CAN bus.



Chapter 3

BIOS Settings

This chapter details instructions for setting BIOS configuration data.

3.1 Introduction

The AMI BIOS ROM has a built-in setup program — the BIOS Setup Utility — that allows users to modify the basic system configuration. All configuration data is stored in battery-backed CMOS to ensure the setup information is retained when the power is turned off.

This chapter describes the basic navigation of the ARK-1221L BIOS setup screens.

3.2 Entering BIOS Setup

Turn on the computer and then press <ESC> or to enter the BIOS Setup menu.

3.2.1 Main Setup

Upon accessing the BIOS Setup Utility, users are presented with the Main setup page. Users can always return to the Main Setup page by selecting the Main tab. The Main BIOS Setup page is shown below.



The Main BIOS setup page has two main frames. The left frame displays all the items accessible on the Main page. Items that are grayed out cannot be configured, whereas items presented in blue text can be configured. The right frame displays the key legend.

Located above the key legend is an area reserved for a text message. When an item is selected in the left frame, the item is presented in white text and often accompanied by a text message.

■ System Date / System Time

Use this option to change the system date and time. Highlight System Date or System Time using the <Arrow> keys. Enter new values via the keyboard. Press the <Tab> key or the <Arrow> keys to move between fields. The date must be entered in MM/DD/YY format, and the time must be entered in HH:MM:SS format.

3.2.2 Advanced Setup

Select the Advanced tab from the BIOS Setup Utility to enter the Advanced BIOS Setup page. Select any of the items in the left frame of the screen, such as CPU Configuration, to access the sub-menu for that item. The options for any of the Advanced BIOS Setup items can be displayed by highlighting the item using the <Arrow> keys. The Advanced BIOS Setup page is shown below:

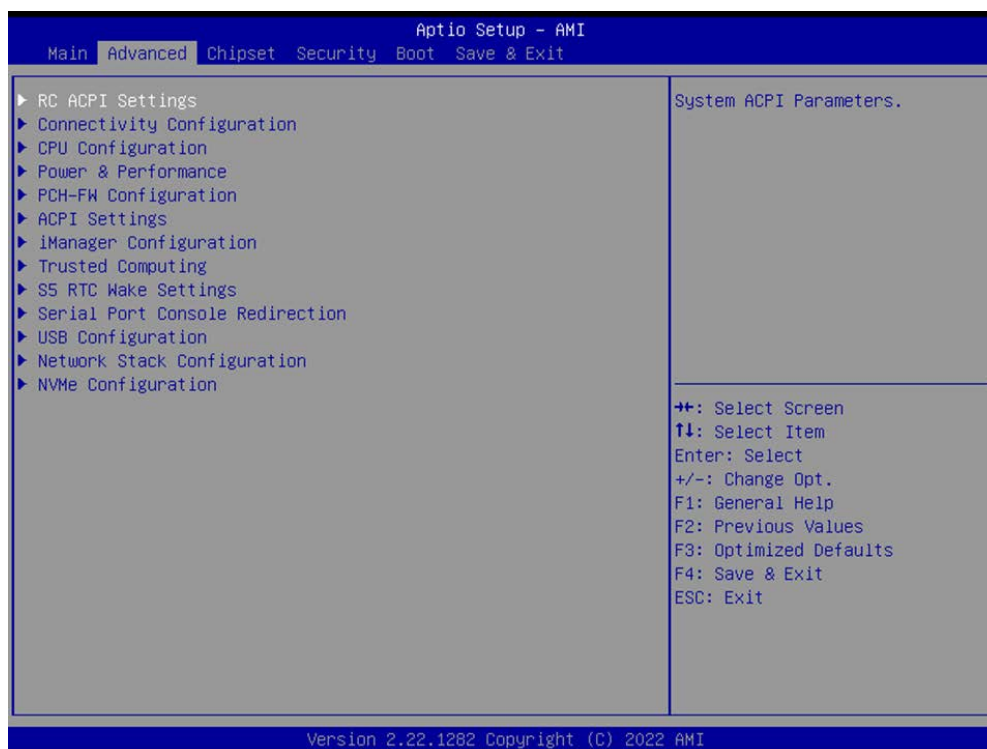

3.2.2.1 RC ACPI Settings

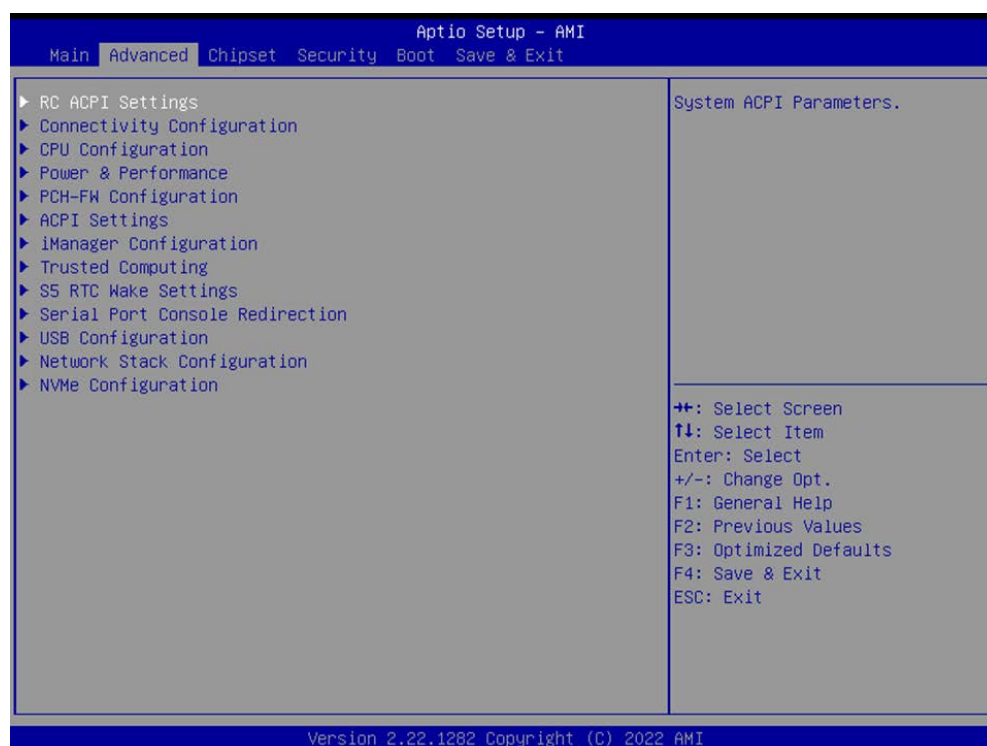

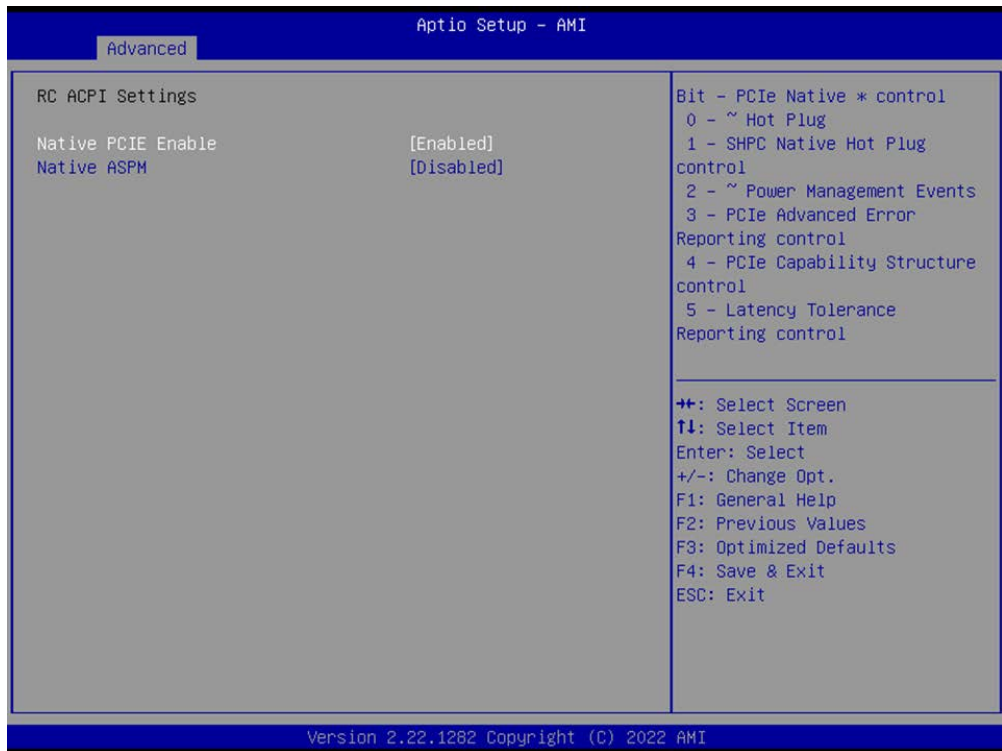

- **Native PCIe Enable**
Enable or disable native PCIe.
- **Native ASPM**
[Enabled] for OS controlled ASPM, [Disabled] for BIOS controlled ASPM.

3.2.2.2 Connectivity Configuration

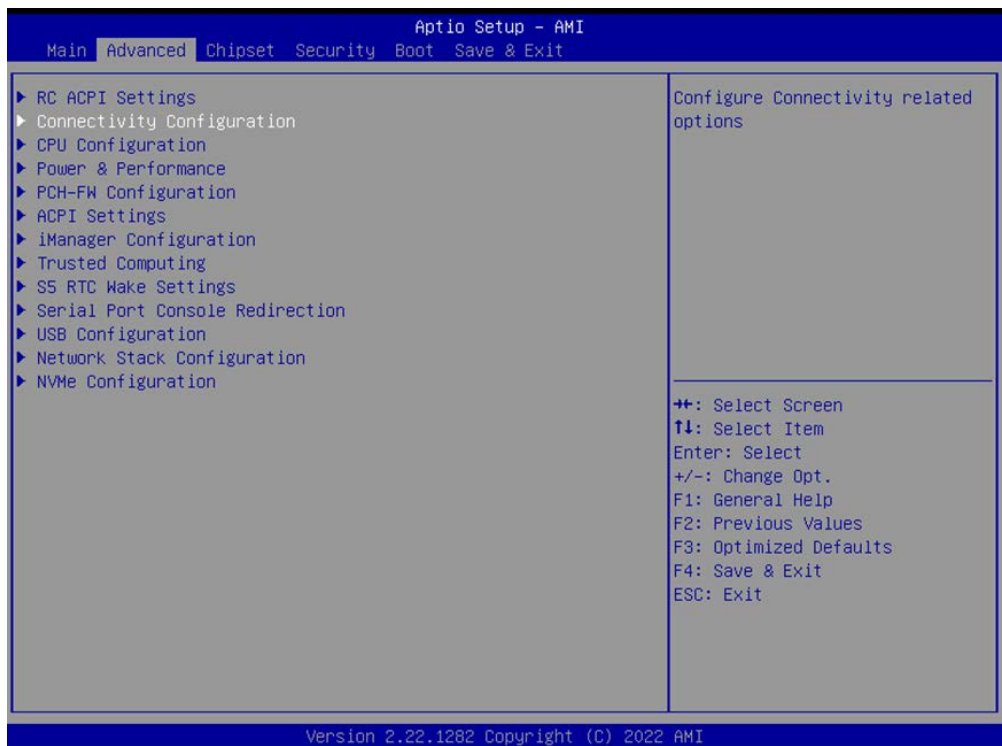

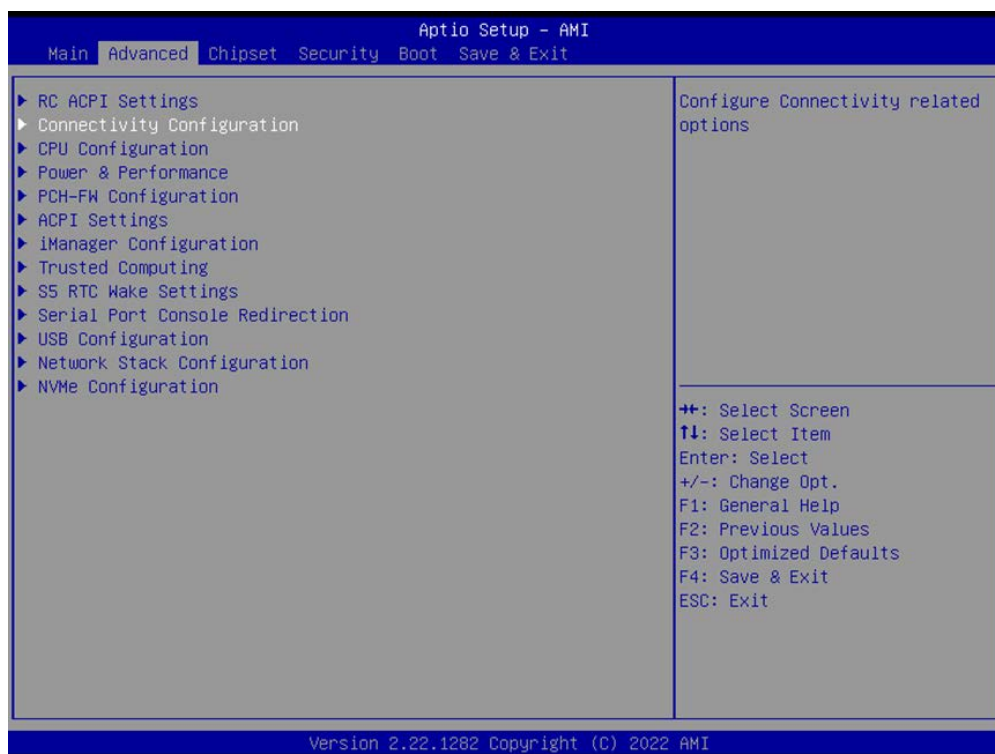

Connectivity Configuration

■ CNVi Mode

[Auto Detection] means that if a discrete solution is discovered, it will be enabled by default. Otherwise integrated solution (CNVi) will be enabled; [Disable Integrated] disables integrated solution.

■ Preboot BLE

It is used to enable/disable the Preboot Bluetooth function.

■ Discrete Bluetooth Module

Serial I/O UART0 needs to be enabled to select the BT module.

■ BT Interrupt Mode

Select routing of interrupt from the BT module.

■ Advanced Settings

Configure ACPI objects for wireless devices.

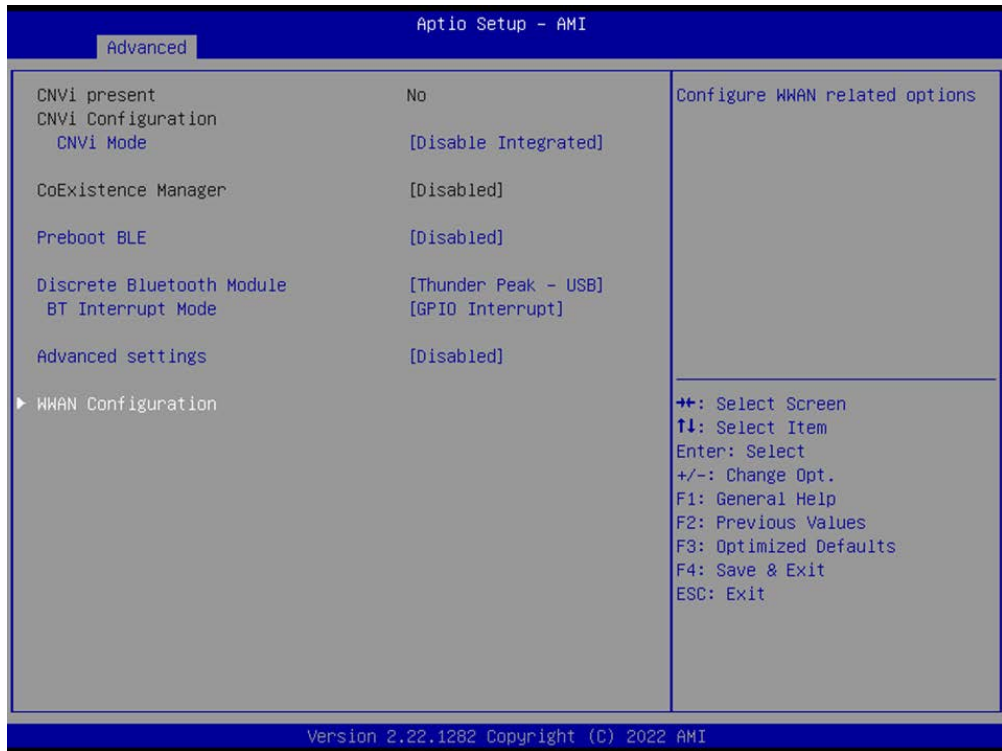

WWAN Configuration

- **WWAN Device**
Enable or disable M.2 WWAN Device

3.2.2.3 CPU Configuration

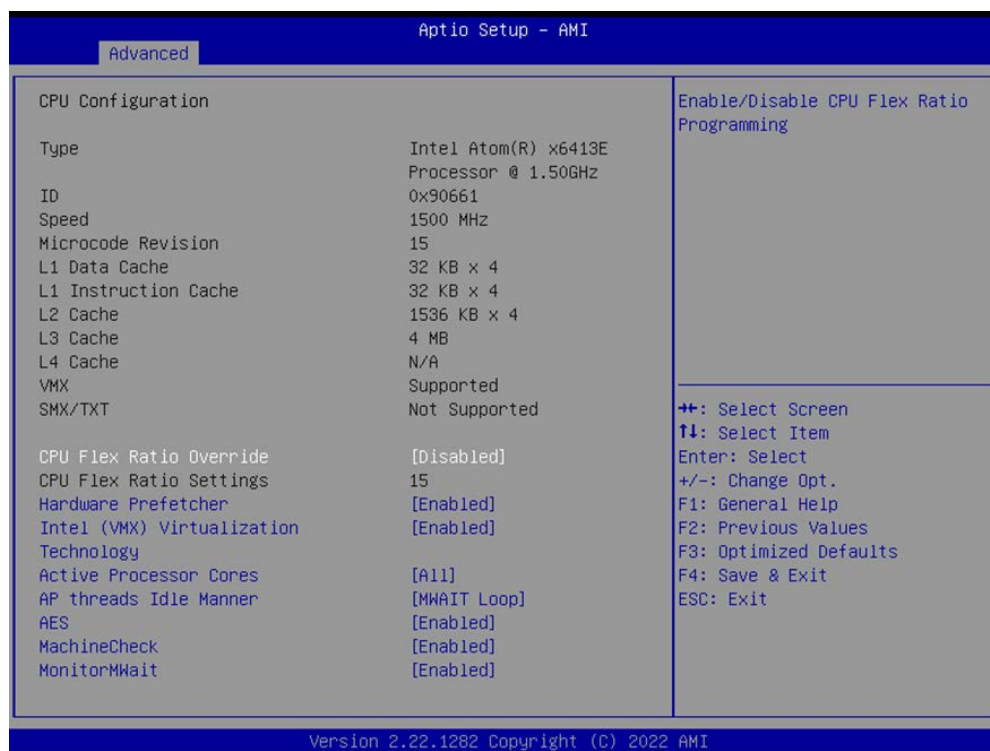
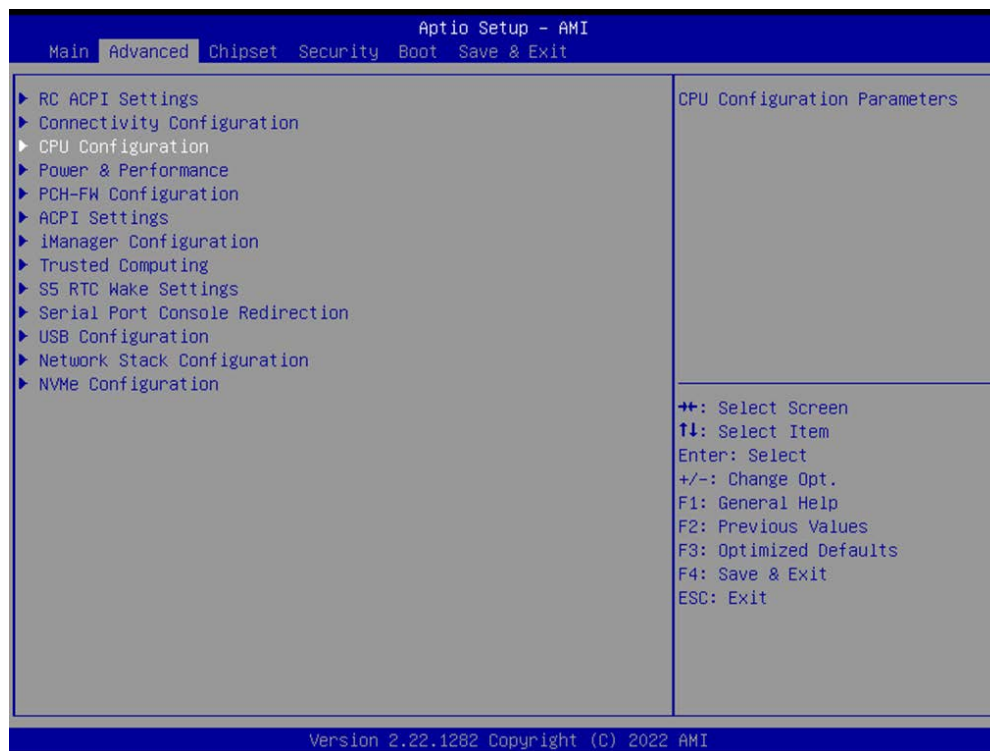

- **CPU Flex Ratio**
Enable or disable CPU Flex Ratio Programming.
- **Hardware Prefetcher**
To turn on/off the MLC streamer prefetcher.
- **Intel® (VMX) Virtualization Technology**

When enabled, a VMM can utilize the additional hardware capabilities provided by Vanderpool Technology.

- **Active Processor Cores**
Number of cores to enable in each processor package.
- **Active Processor Cores**
Number of cores to enable in each processor package.
- **AP threads Idle Manner**
AP threads Idle Manner for waiting signal to run.
- **AES**
Enable/disable AES (Advanced Encryption Standard).
- **MachineCheck**
Enable/disable Machine Check.
- **MonitorMWait**
Enable/disable MonitorMWait.

3.2.2.4 Power & Performance

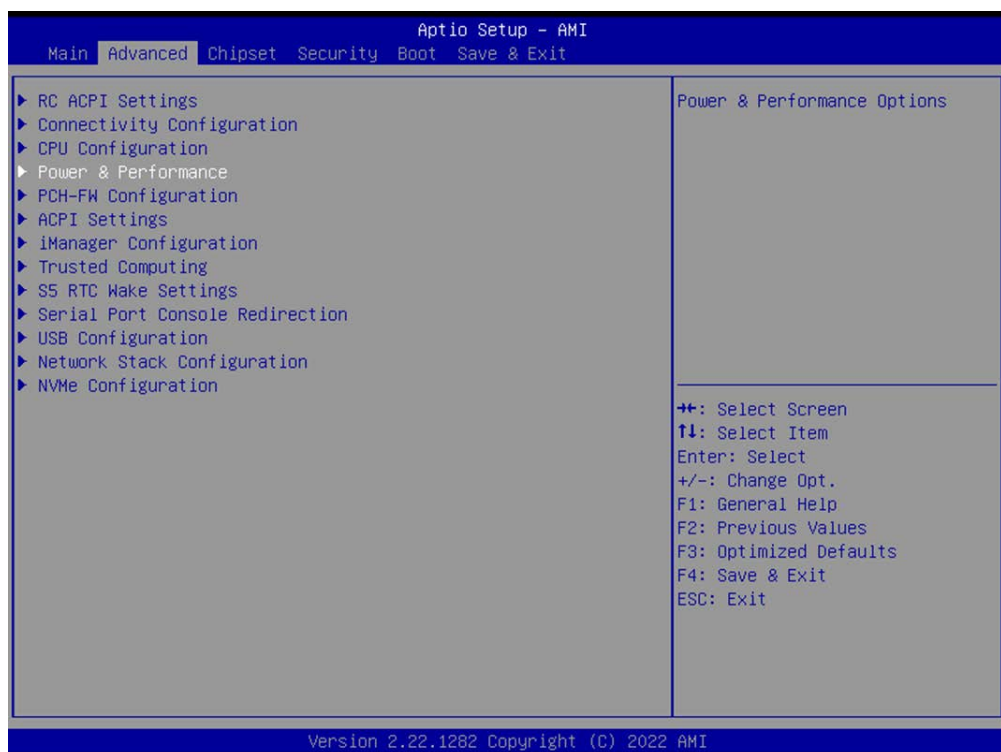

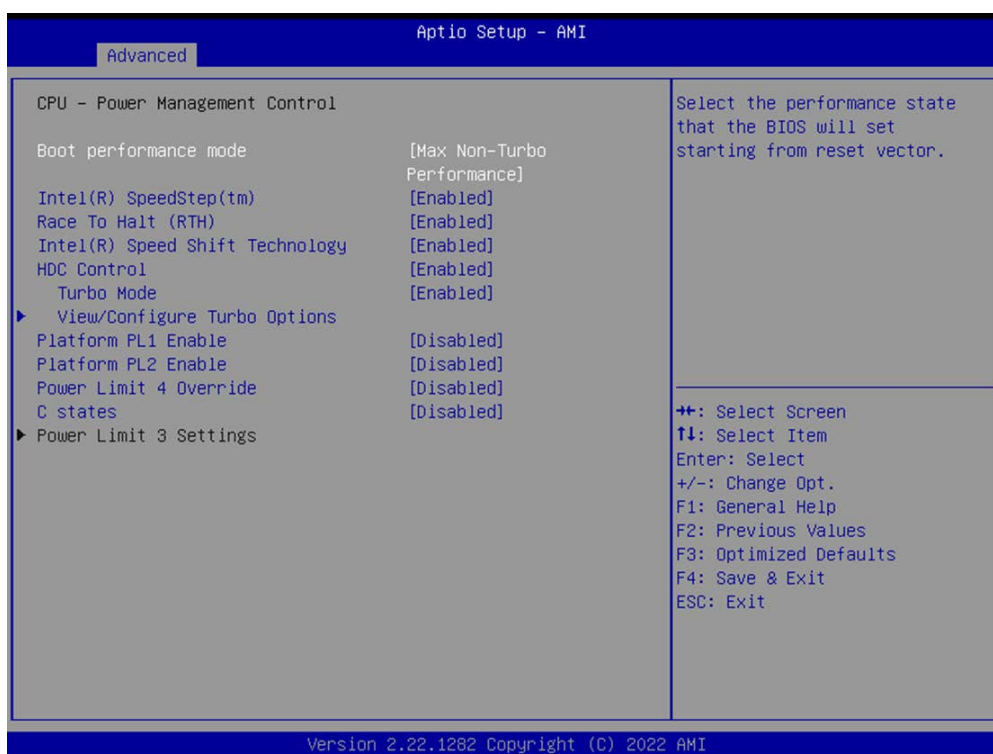

CPU - Power Management Control

- **Boot Performance Mode**
Select the performance state that the BIOS will set starting from the reset vector.
- **Intel® SpeedStep®**
Allows more than two frequency ranges to be supported.
- **Race to Halt (RTH)**

Enable/disable the Race to Halt feature. RTH will dynamically increase CPU frequency in order to enter package C-state faster to reduce overall power.

- **Intel® Speed Shift Technology**
Enable/disable Intel® Speed Shift Technology support.
- **HDC Control**
This option allows HDC configuration. [Enabled] can be set by the OS if OS native support is available.
- **Turbo Mode**
Enable/disable processor Turbo Mode.
- **Platform PL1 Enable**
Enable/disable platform power limit 1 programming.
- **Platform PL2 Enable**
Enable/disable platform power limit 2 programming.
- **Power Limit 4 Override**
Enable/disable power limit 4 override.
- **C states**
Enable/disable CPU Power Management. Allow CPU to go to C states when it's not 100% utilized.

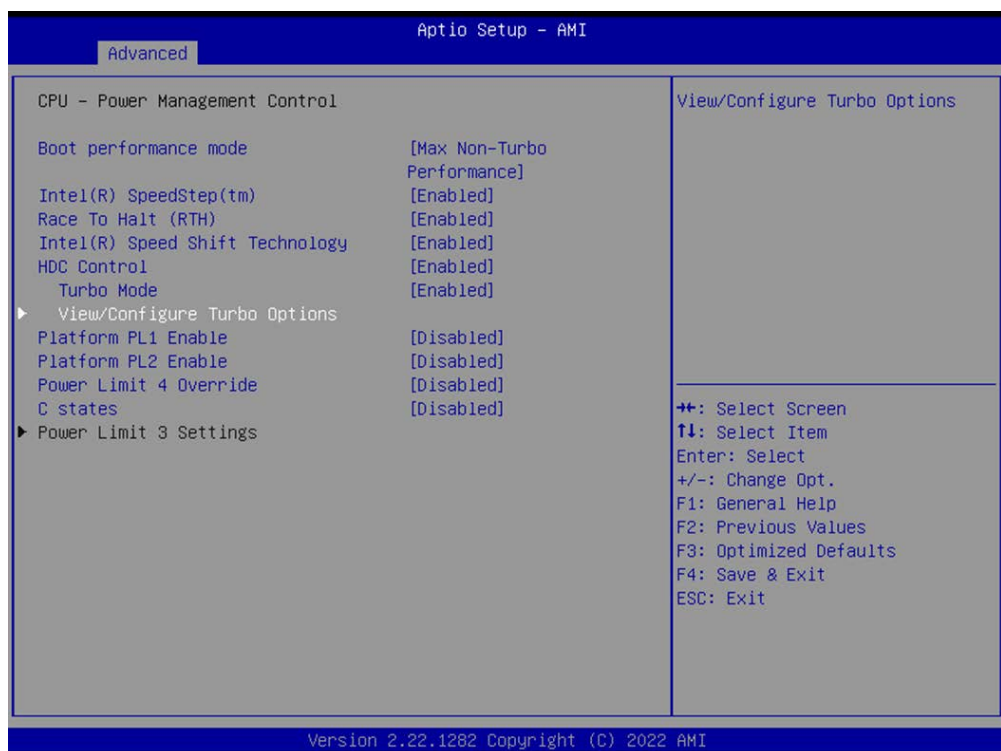

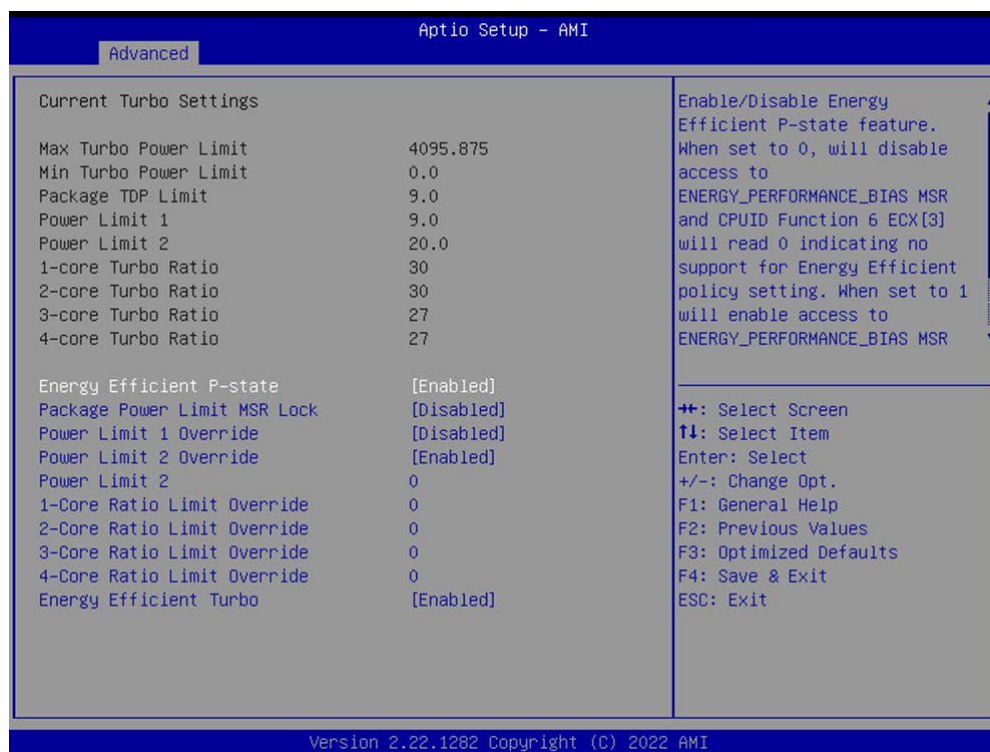

View/Configure Turbo Options

- **Energy Efficient P-state**
- **Package Power Limit MSR Lock**
- **Power Limit 1 Override**
- **Power Limit 2 Override**
- **Power Limit 2**
- **1-Core Ratio Limit Override**
- **2-Core Ratio Limit Override**
- **3-Core Ratio Limit Override**
- **4-Core Ratio Limit Override**
- **Energy Efficient Turbo**



GT - Power Management Control

- **Maximum GT frequency**
Maximum GT frequency is limited by the user.
- **Disable Turbo GT frequency**
Enabled: Disables Turbo GT frequency. Disabled: GT frequency is not limited.

3.2.2.5 PCH-FW Configuration

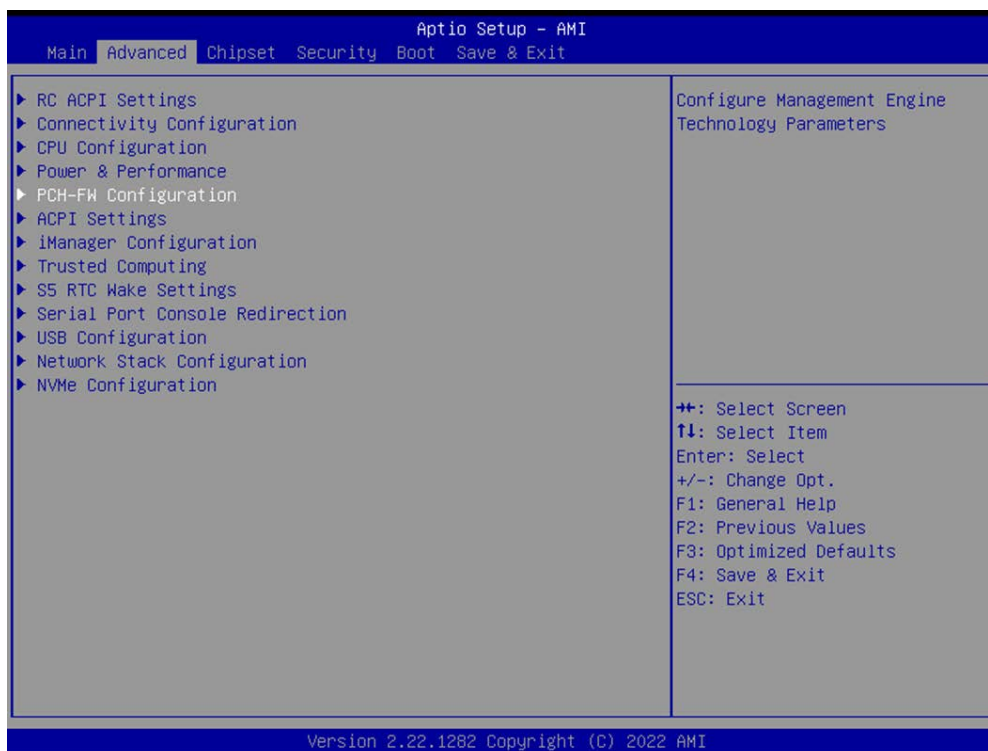

- **ME State**
When disabled, ME will be put into ME Temporarily Disabled Mode.
- **ME Unconfig on RTC Clear**
When disabled, ME will not be unconfigured on RTC Clear.
- **Core Bios Done Message**
Enable/disable Core Bios Done message sent to ME.

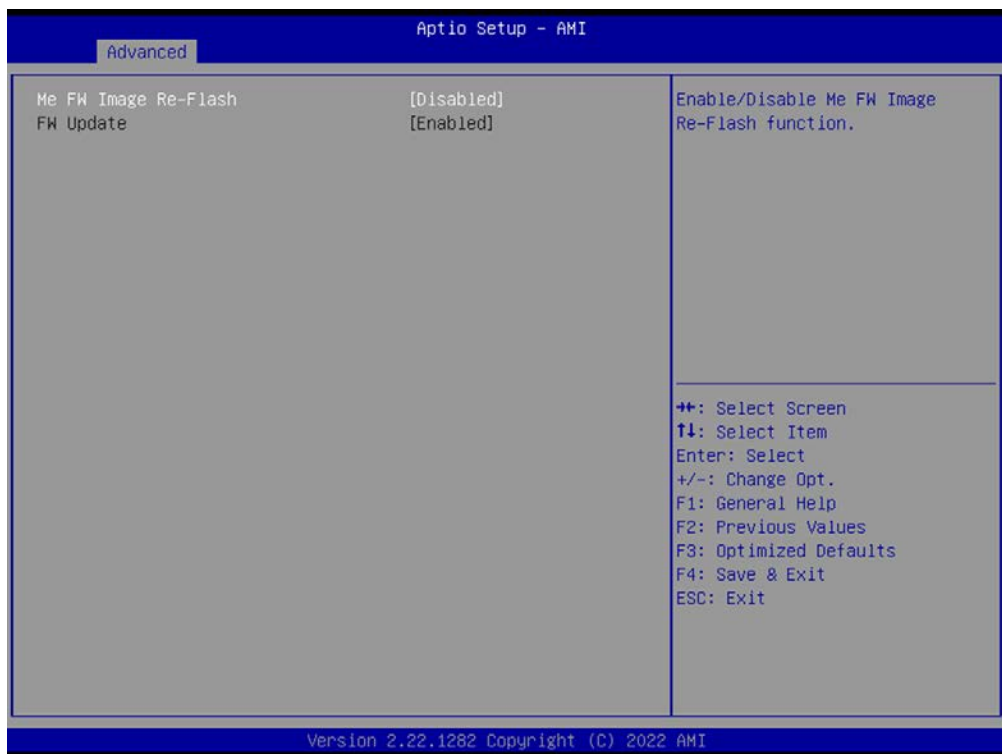
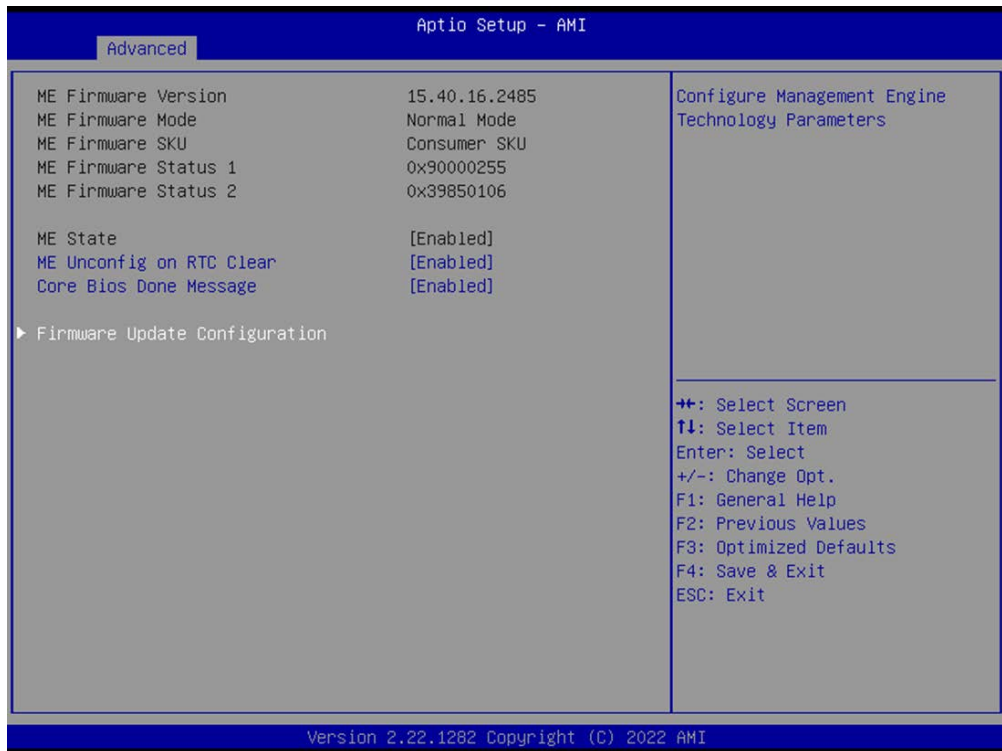

Firmware Update Configuration

- Me FW Image Re-Flash
- FW Update

3.2.2.6 ACPI Settings

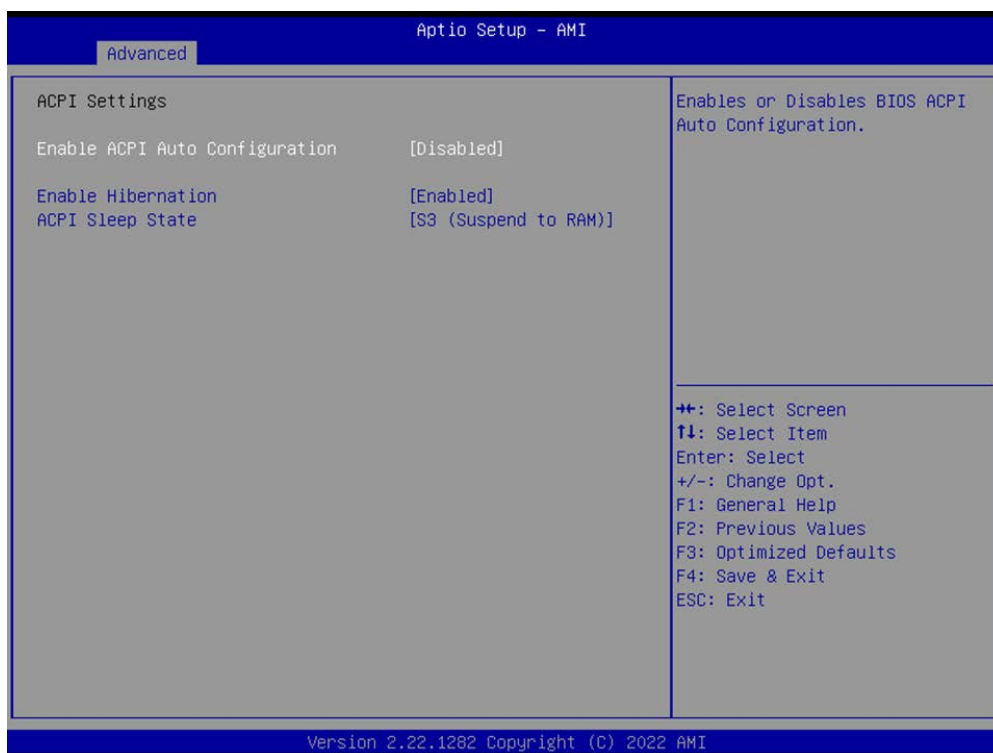
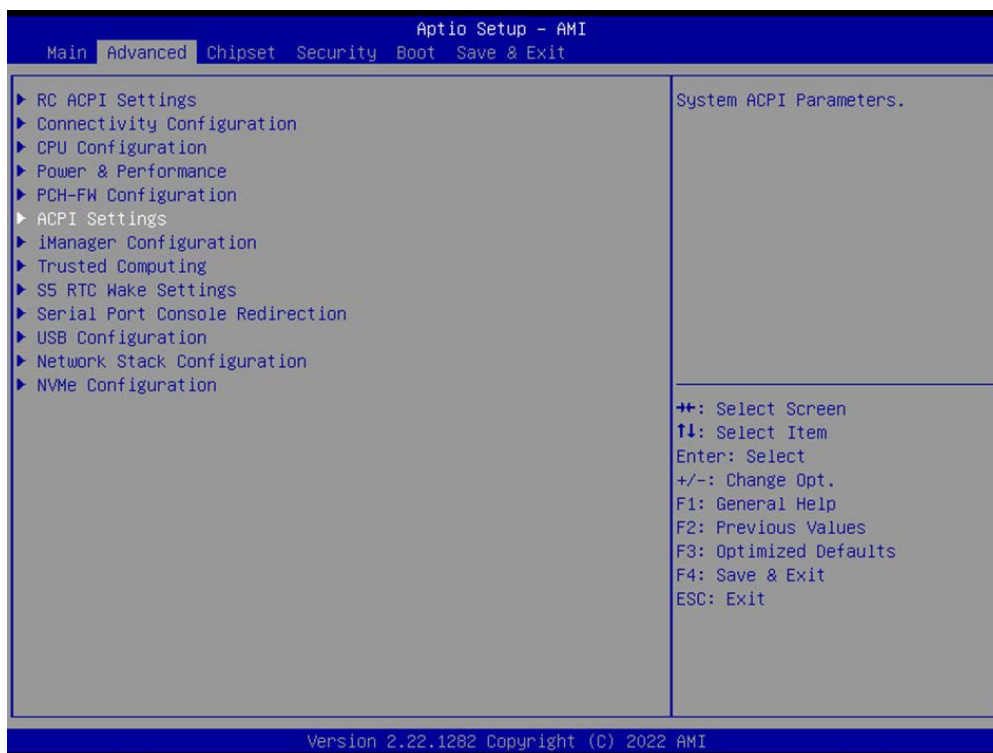

- **Enable ACPI Auto Configuration**
Enables or disables BIOS ACPI Auto Configuration.
- **Enable Hibernation**
Enables or disables the System ability to Hibernate (OS/S4 Sleep State). This option may not be effective with some operating systems.
- **ACPI Sleep State**

Select the highest ACPI sleep state the system will enter when the SUSPEND button is pressed.

3.2.2.7 iManager Configuration

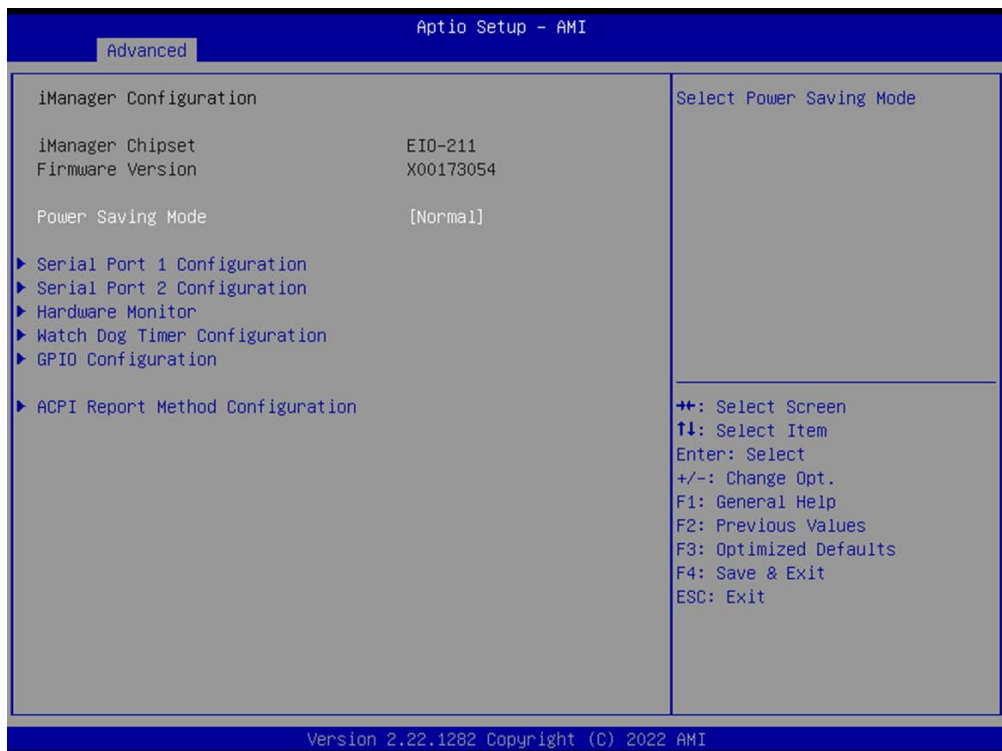
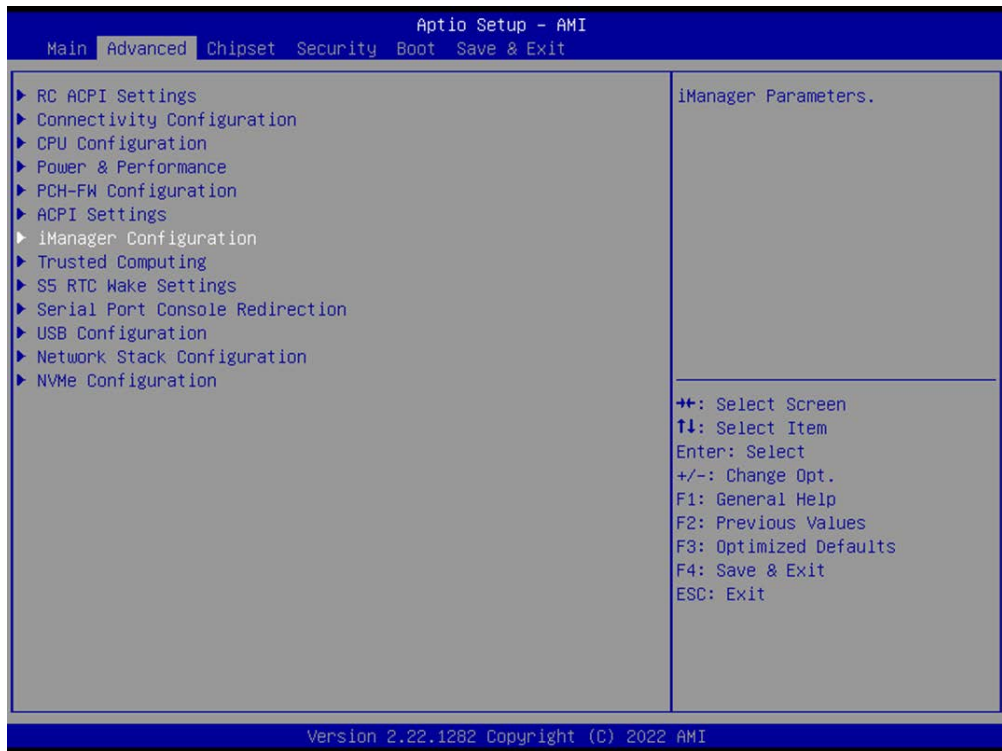

- **Power Saving Mode**
Select Power Saving Mode: Normal or Deep Sleep

Note!  To be ErP ready, please select Deep Sleep and also configure the jumper accordingly (please check section 2.2). By reducing the power loss under S5 mode with the ERP1 jumper setting, it complies with ErP regulations.

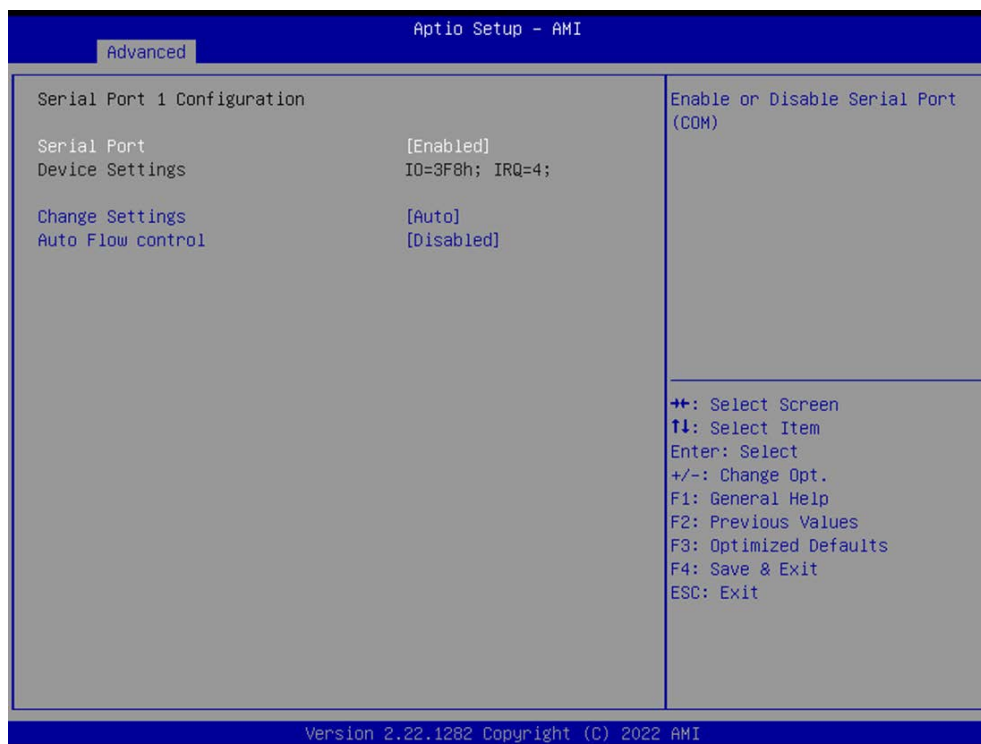
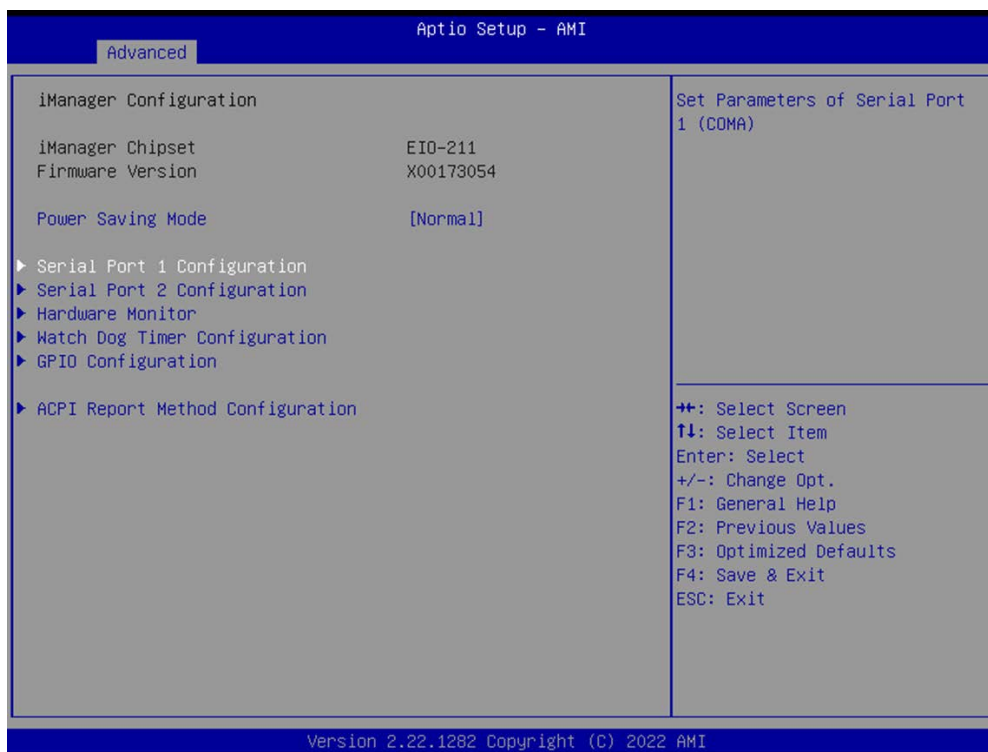

Serial Port 1 to 2 Configuration

- **Serial Port**
Enable/disable serial port.
- **Change Settings**
Select optimal settings for Super IO device.
- **Auto Flow control**
Enable/disable the Auto Flow control function.

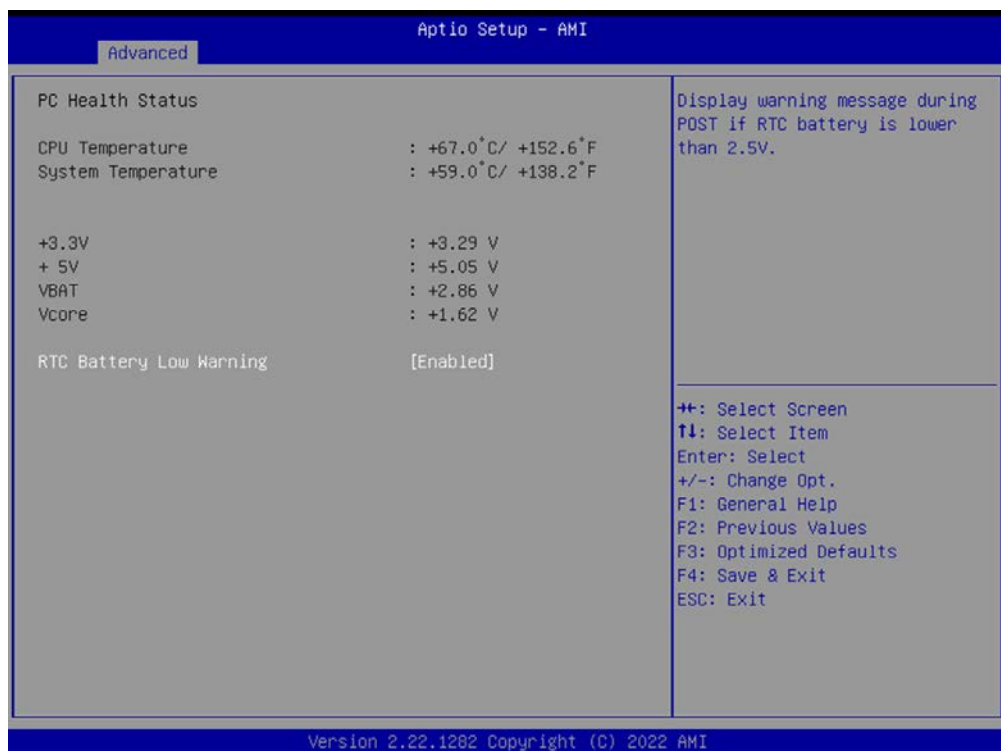
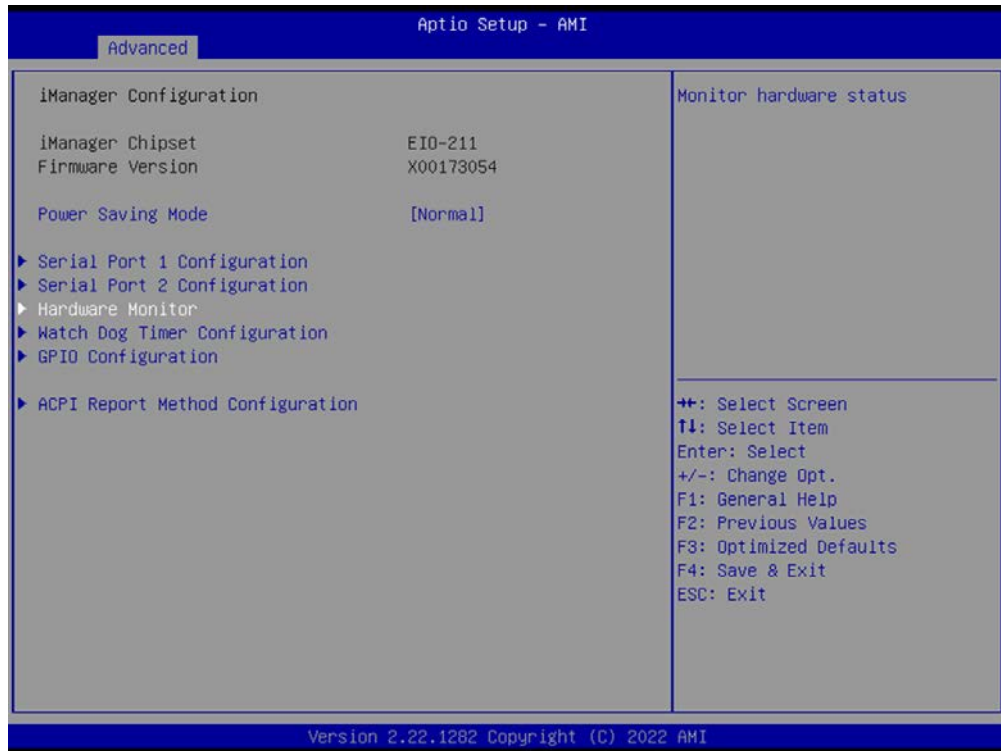

Hardware Monitor

Provides hardware monitoring information

- **RTC Battery Low Warning**

Enable to display a warning message during POST if the RTC battery is lower than 2.5 V.

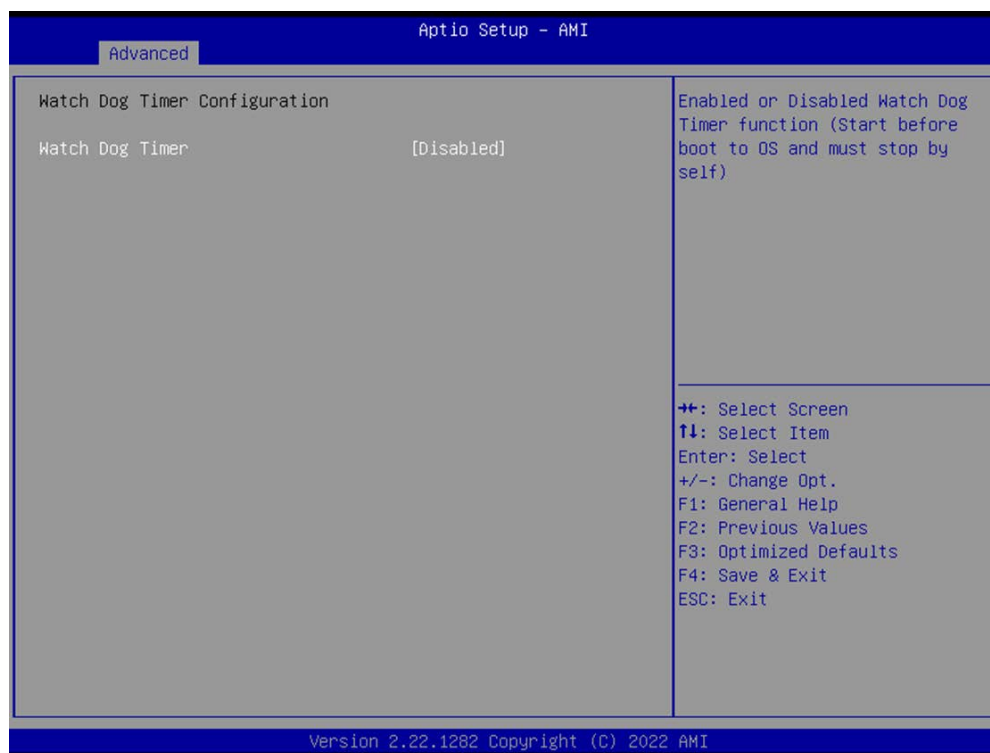

Watch Dog Timer Configuration

■ Watch Dog Timer

Enable or disable the Watch Dog Timer function (Start before boot to OS and it must stop by itself).

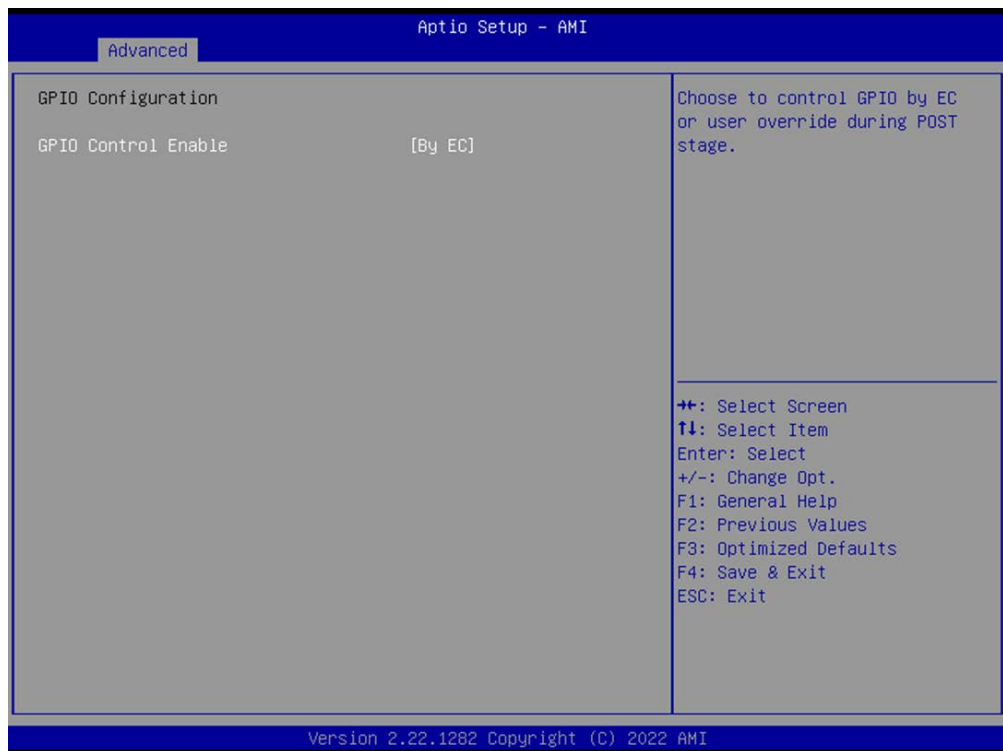
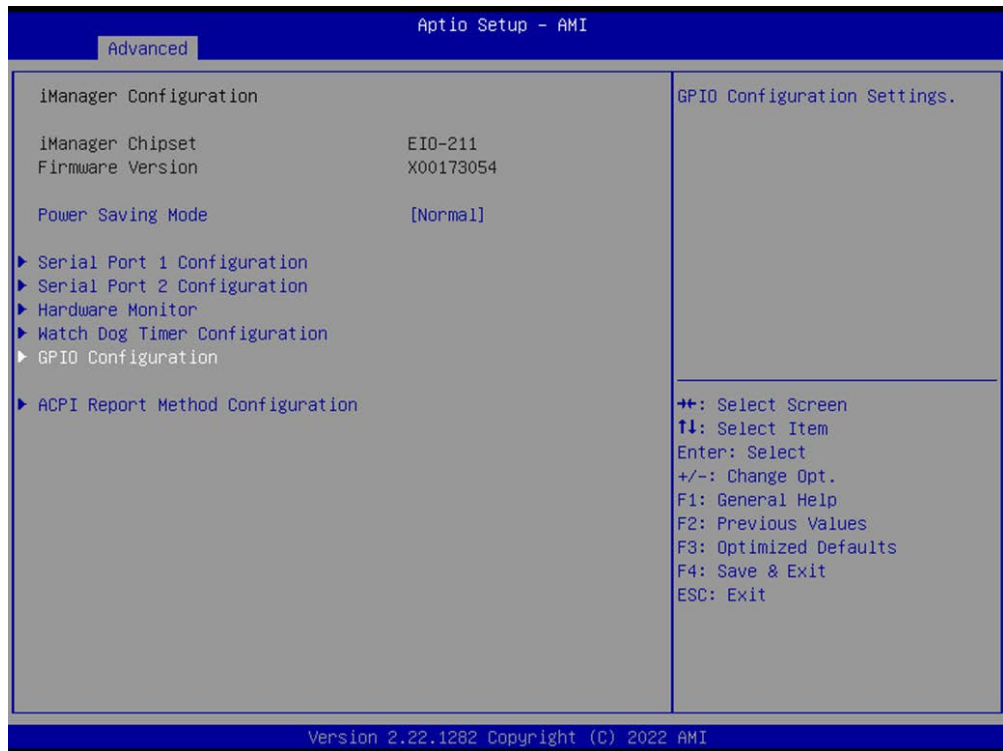

GPIO Configuration

■ GPIO Control Enable

Select to control GPIO by EC or user override during the POST stage.

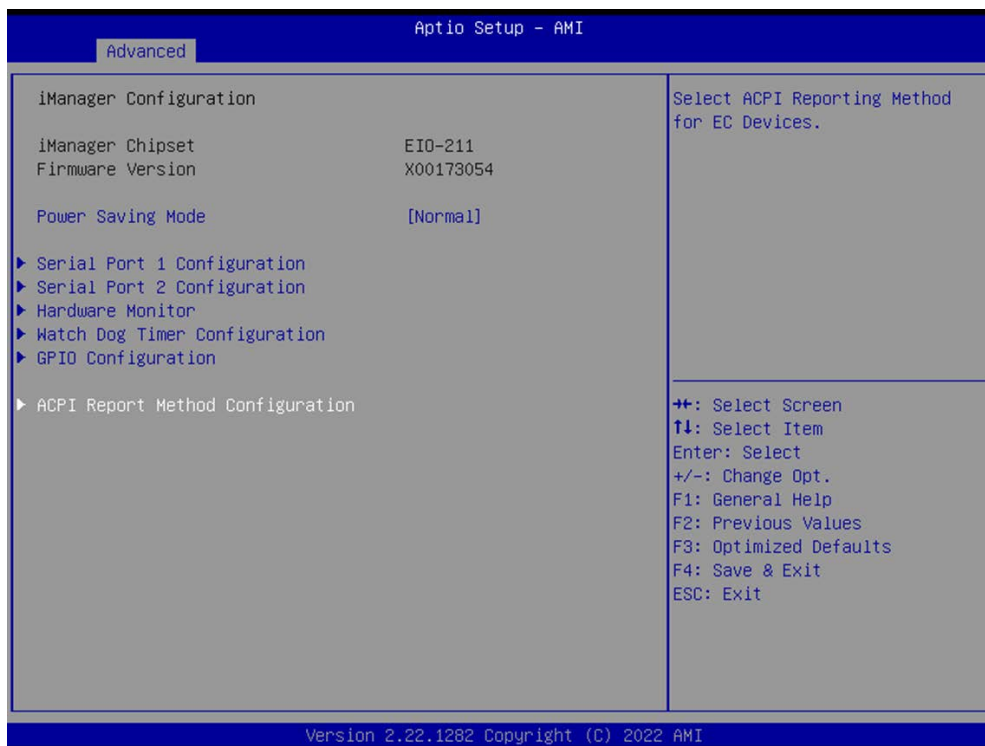

ACPI Report Method Configuration

- **ACPI Report Method Control**
[Default] for most ACPI OS. [Custom] for 3rd party driver installation.

3.2.2.8 Trusted Computing

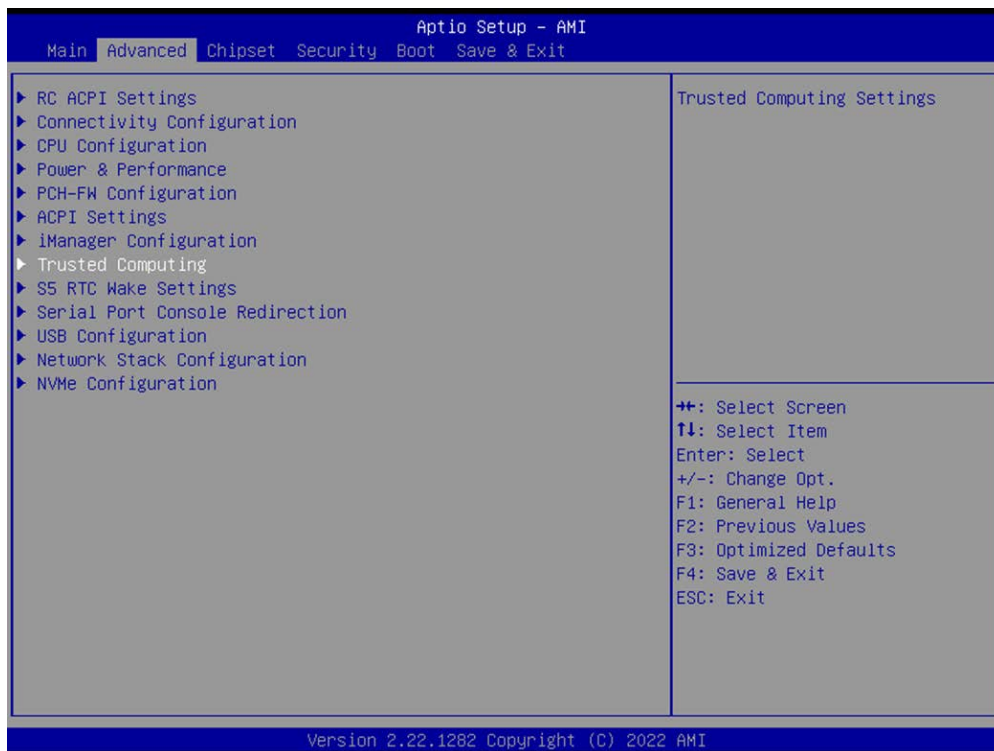

- **Security Device Support**
Enables or disables BIOS support for a security device.
- **SHA256 PCR Bank**
Enable or disable SHA256 PCR Bank.
- **Pending operation**
Schedule an operation for the security device.

- **Platform Hierarchy**
Enable or disable Platform Hierarchy.
- **Storage Hierarchy**
Enable or disable Storage Hierarchy.
- **Endorsement Hierarchy**
Enable or disable Endorsement Hierarchy.
- **Physical Presence Spec Version**
Select to tell the OS to support PPI Spec Version 1.2 or 1.3. Note some HCK tests might not support 1.3.
- **TPM 2.0 Interface Type**
Select the Communication Interface to the TPM 2.0 Device.
- **Device Select**
TPM 1.2 will restrict support to TPM 1.2 devices; TPM 2.0 will restrict support to TPM 2.0 devices; Auto will support both with the default set to TPM 2.0 devices if not found; TPM 1.2 devices will be enumerated.

3.2.2.9 S5 RTC Wake Settings

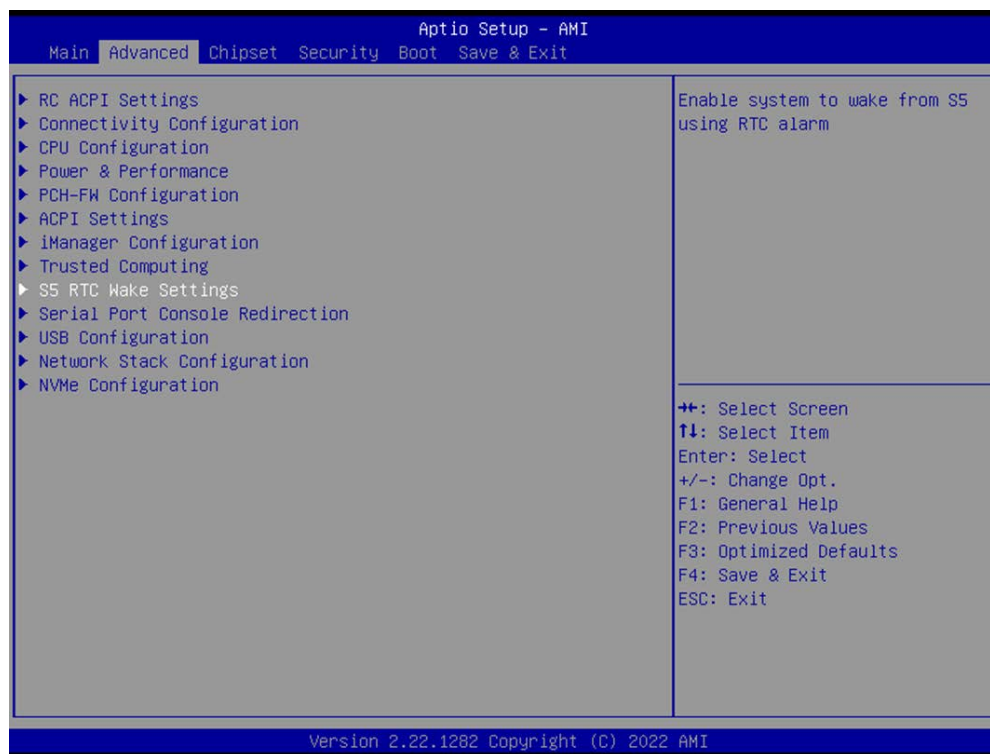



- **Wake System from S5**

Enable or disable system wake-on-alarm event. When enabled, System will wake on the hr:min:sec specified.

3.2.2.10 Serial Port Console Redirection

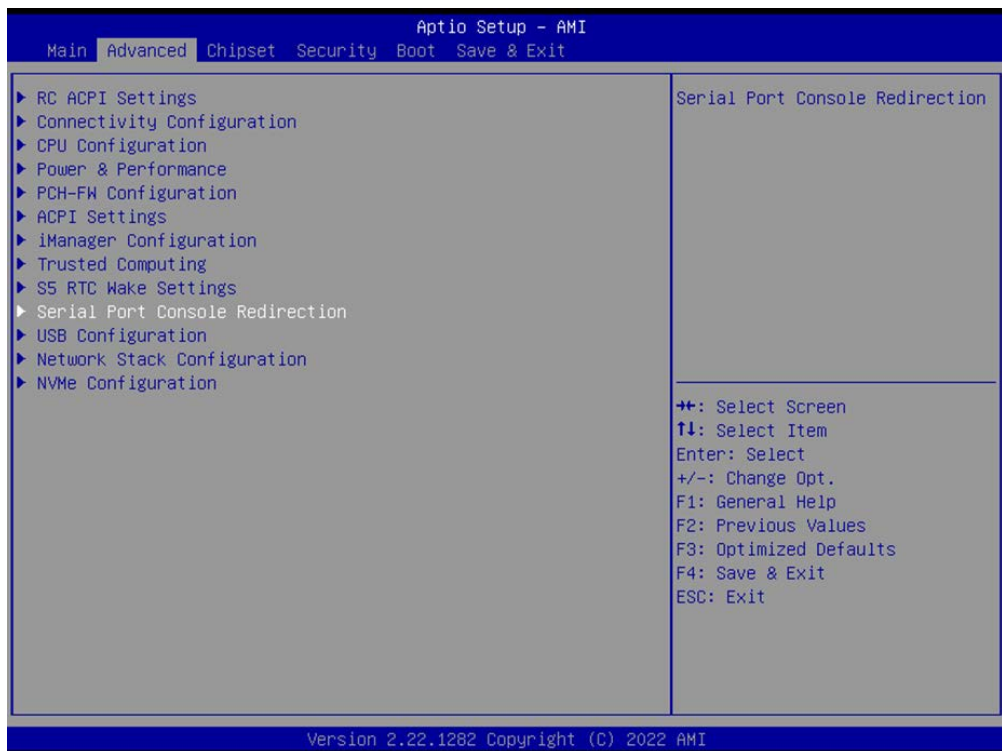

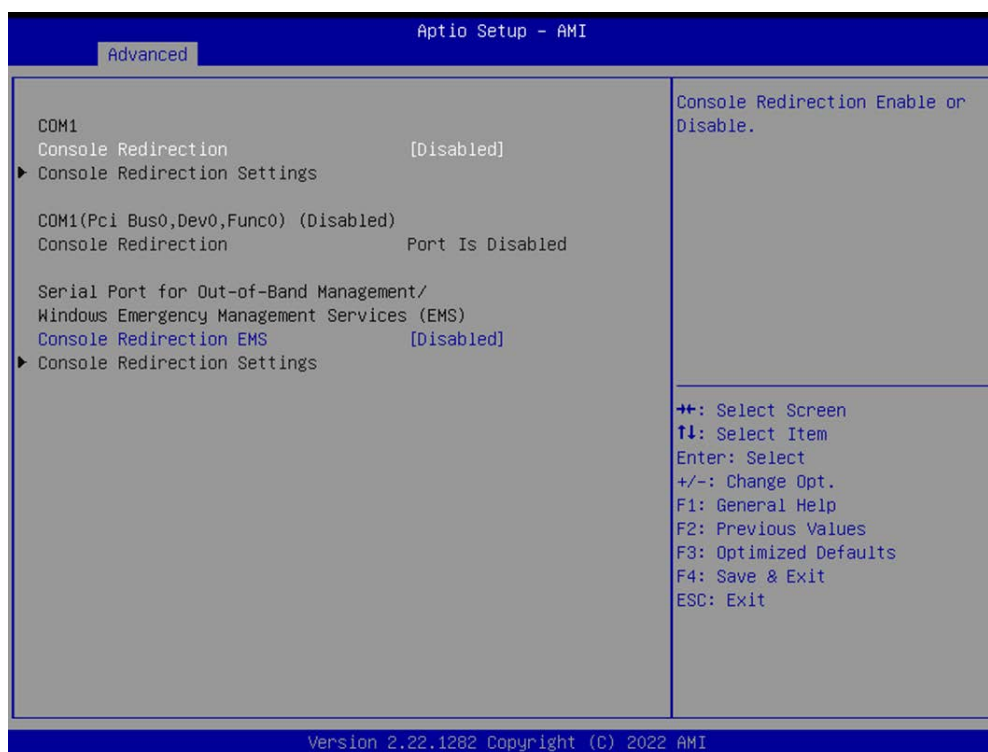

- **Console Redirection**
Console Redirection Enable or Disable.
- **Console Redirection EMS**
Console Redirection Enable or Disable.

3.2.2.11 USB Configuration

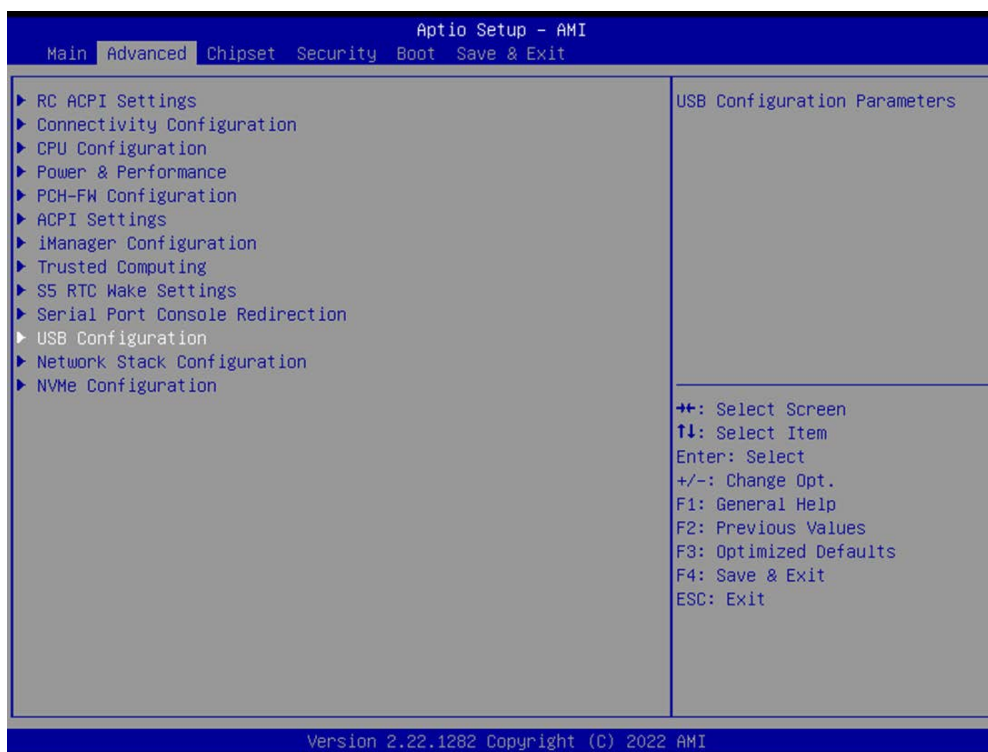

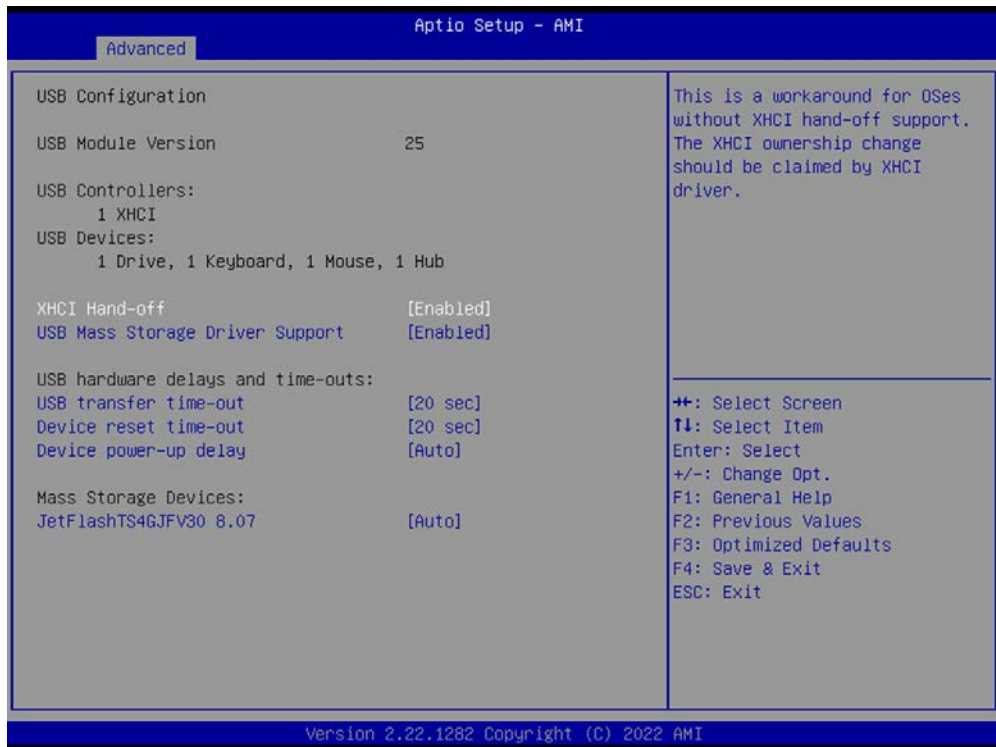

- **XHCI Hand-Off**
This is a workaround for the OS without XHCI hand-off support.
- **USB Mass Storage Driver Support**
Enable/disable USB Mass Storage Driver Support.
- **USB transfer time-out**
The time-out value for control, bulk, and interrupt transfers.
- **Device Reset time-out**
USB mass storage device Start Unit command time-out.
- **Device power-up delay**
Maximum time the device will take before it properly reports itself to the Host Controller.

3.2.2.12 Network Stack Configuration

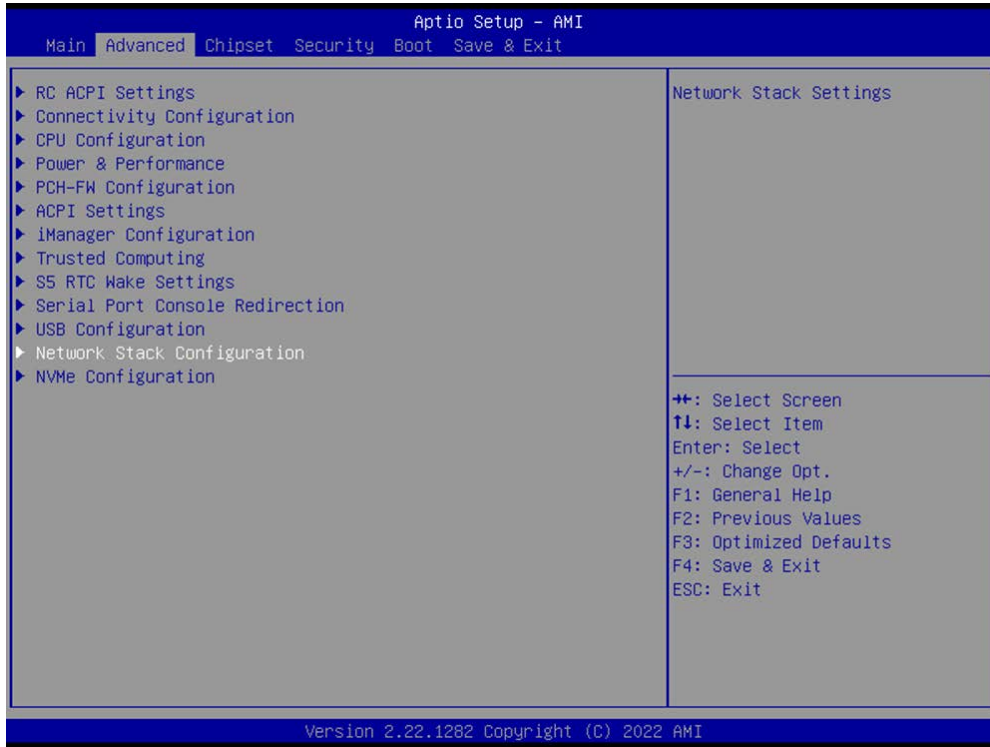

- **Network Stack**
Enable/disable the UEFI network stack.

3.2.2.13 NVMe Configuration

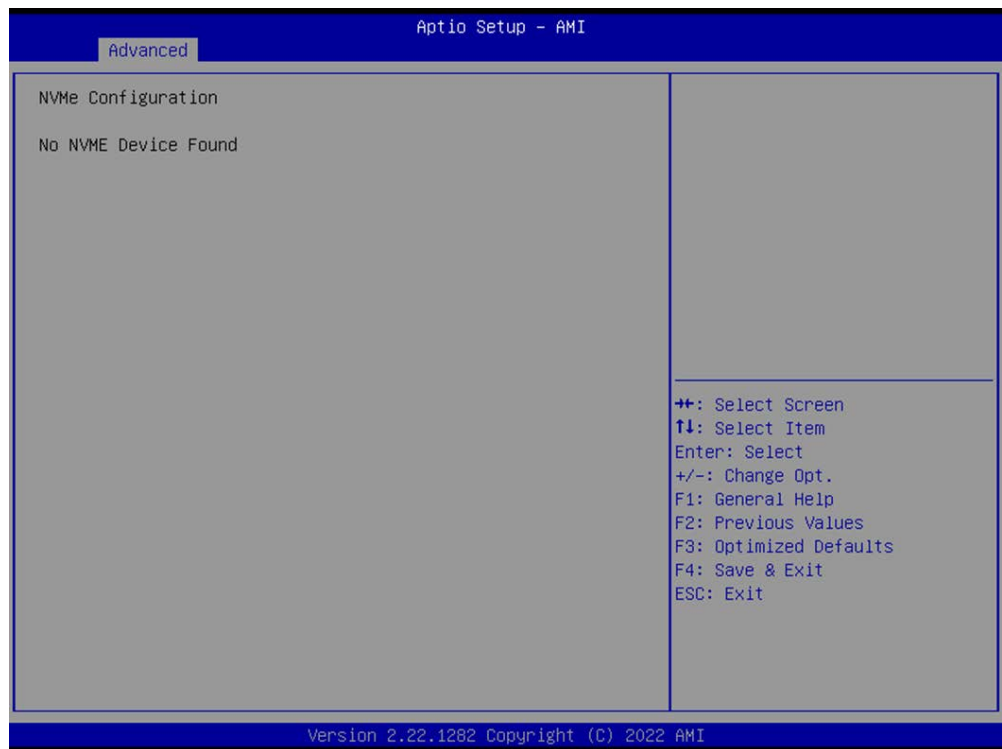
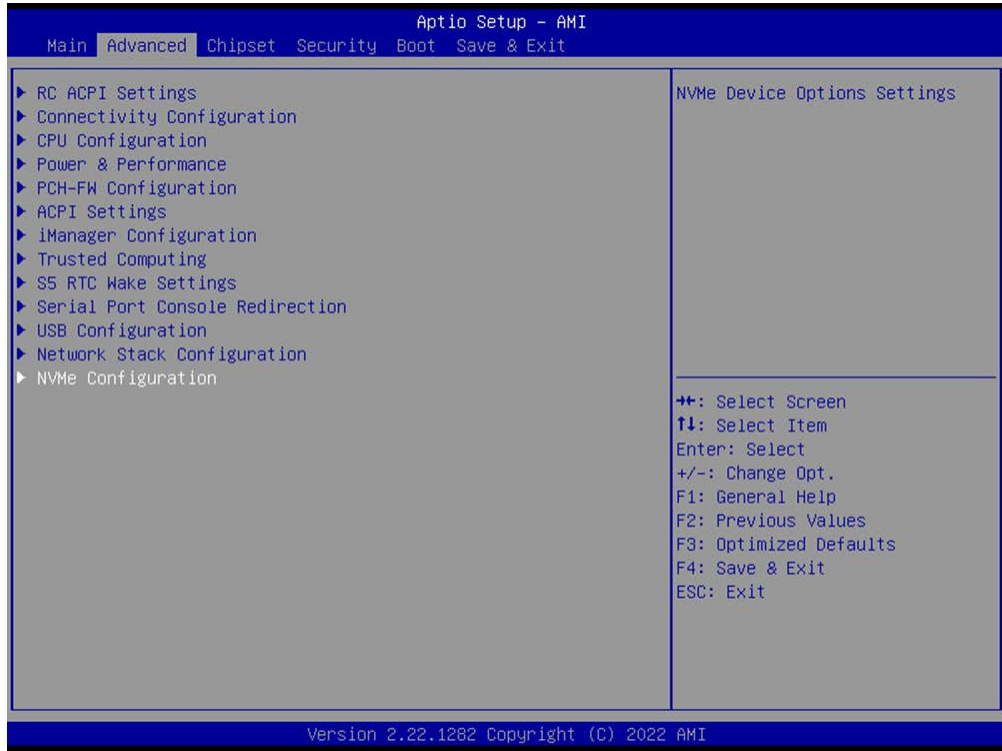

Provides NVMe device information.

3.2.3 Chipset

3.2.3.1 System Agent (SA) Configuration

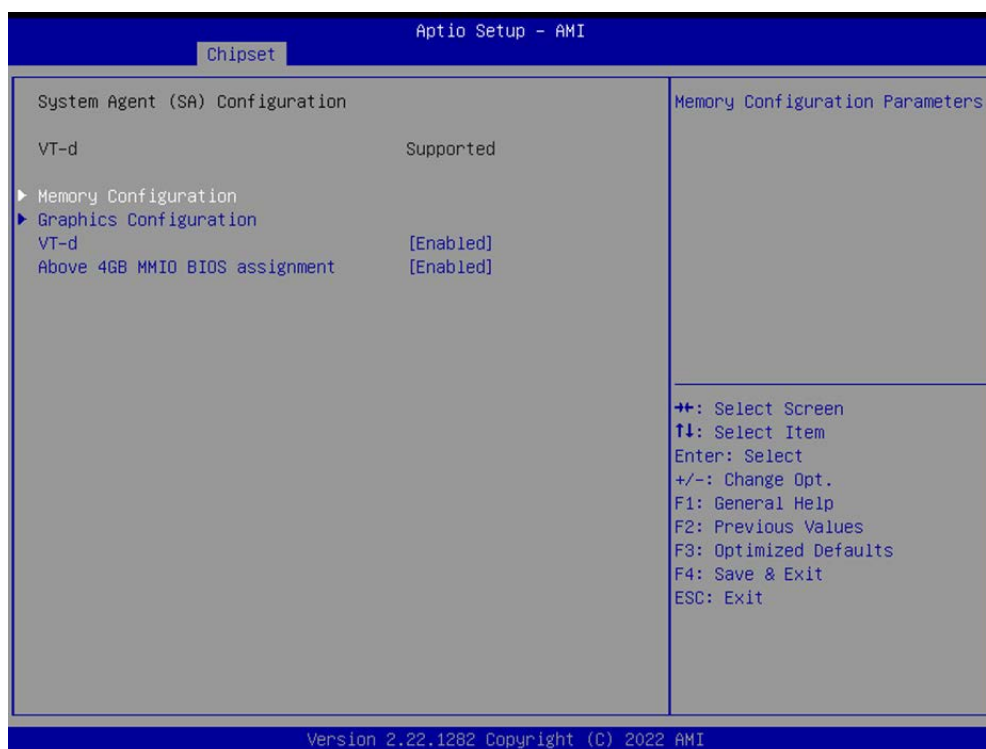

- **VT-d**
VT-d capability
- **Above 4GB MMIO BIOS assignment**

Enable/disable above 4GB MemoryMappedIO BIOS assignment. This is enabled automatically when the Aperture Size is set to 2048MB.

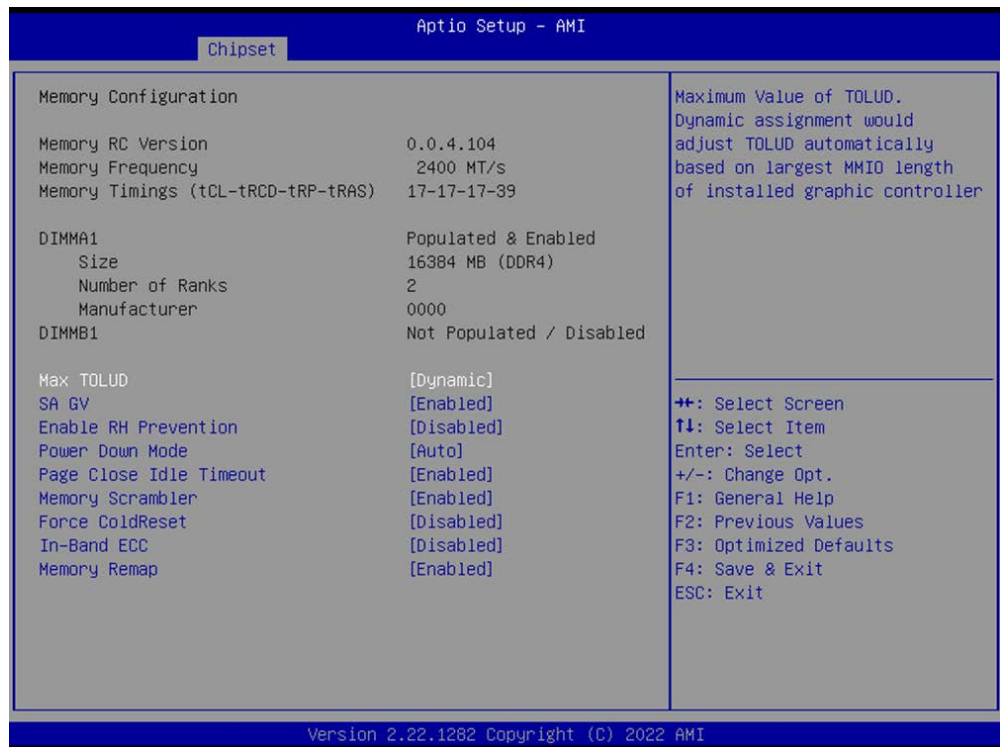

Memory Configuration

- Max TOLUD
- SA GV
- Enable RH Prevention
- Power Down Mode

- Page Close Idle Timeout
- Memory Scrambler
- Force ColdReset
- In-Band ECC
- Memory Remap

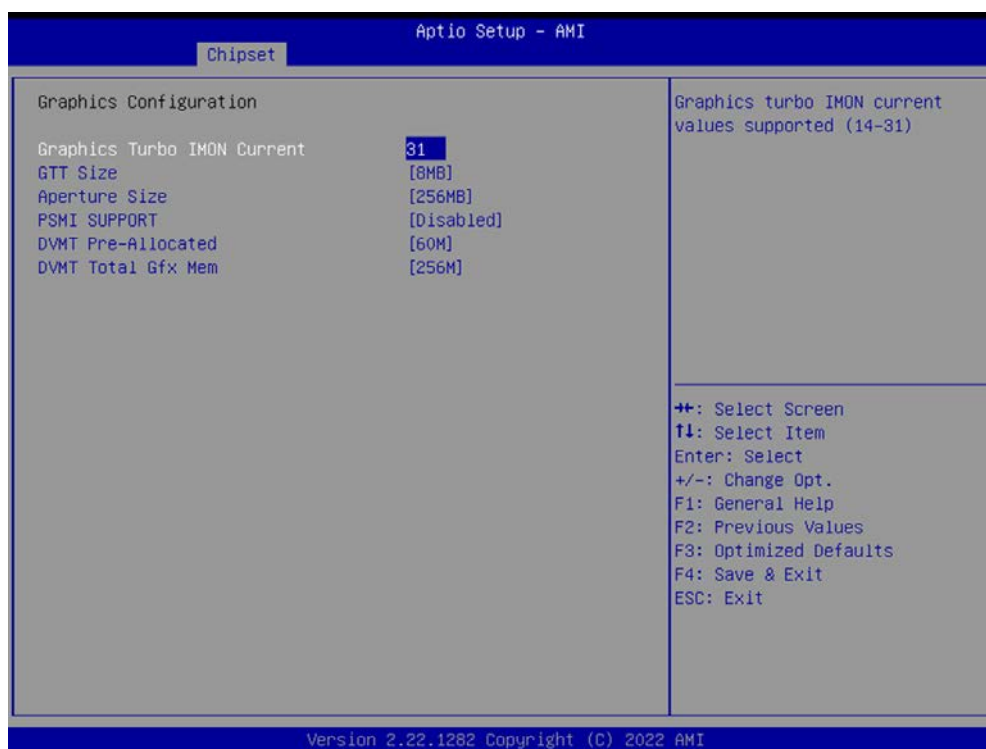

Graphics Configuration

- Graphics Turbo IMON Current

- **GTT Size**
- **Aperture Size**
- **PSMI Support**
- **DVMT Pre-Allocated**
- **DVMT Total Gfx Mem**

3.2.3.2 PCH-IO Configuration





PCI Express Configuration

- **DMI Link ASPM Control**
The control of Active State Power Management of the DMI Link.
- **Port8xh Decode**
PCI Express Port8xh Decode enable/disable.
- **Peer Memory Write Enable**
Peer Memory Write enable/disable.
- **Compliance Test Mode**
Enable when using compliance Load Board.
- **PCH PCI Express Clock Gating**
Enable/disable PCH PCI Express Clock Gating (Power Management) for Each Root Port.
- **PCIe function swap**
When disabled, this prevents PCIe Root Port function swap.

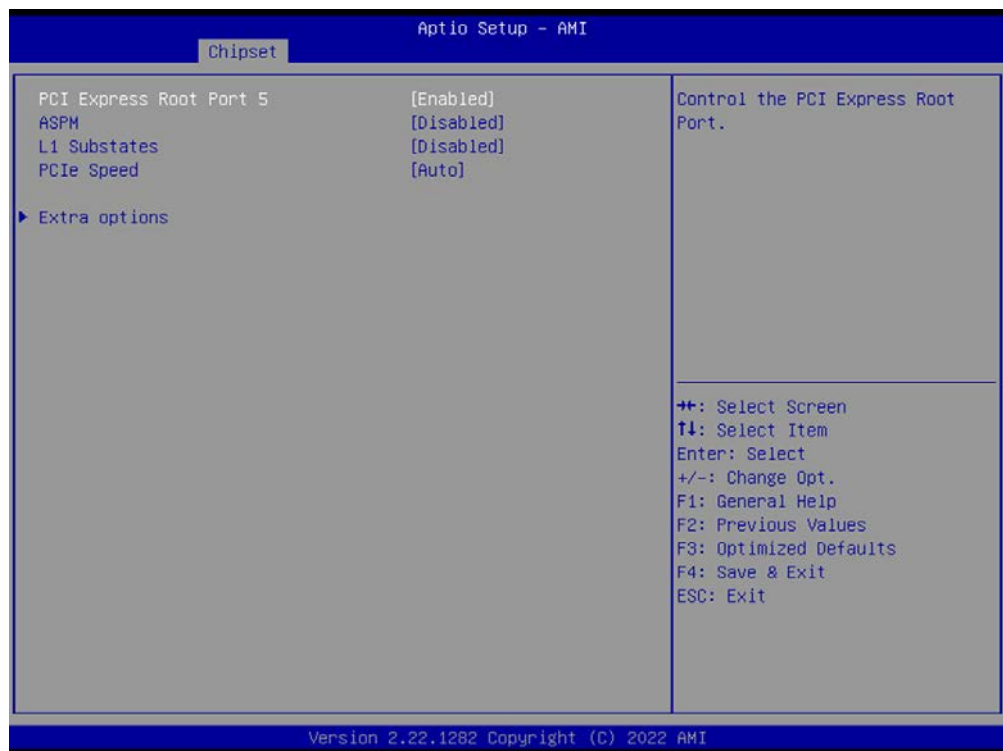
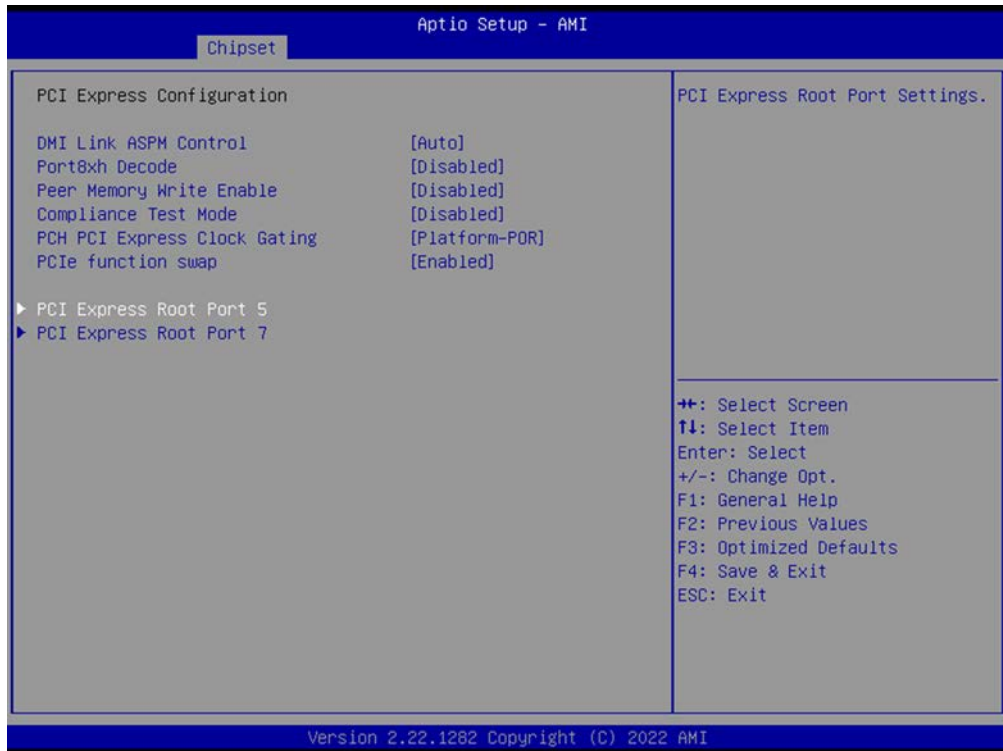

PCI Express Root Port 5

- **PCI Express Root Port 5**
- **ASPM**
- **PCIe Speed**

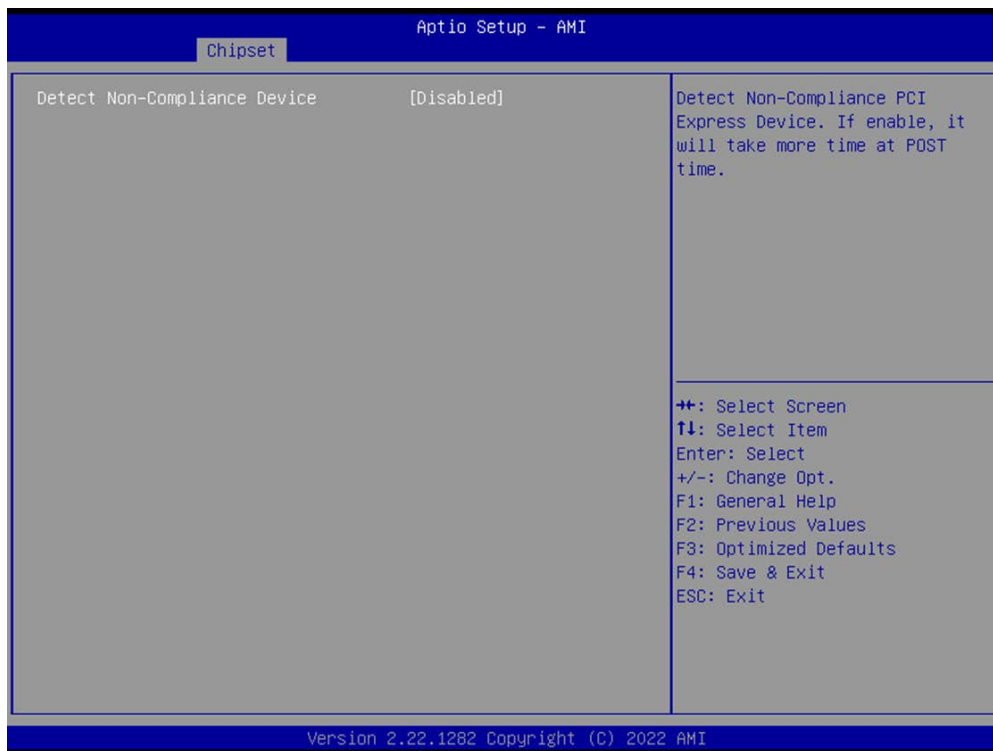

Extra Options

- **Detect Non-Compliant Device**

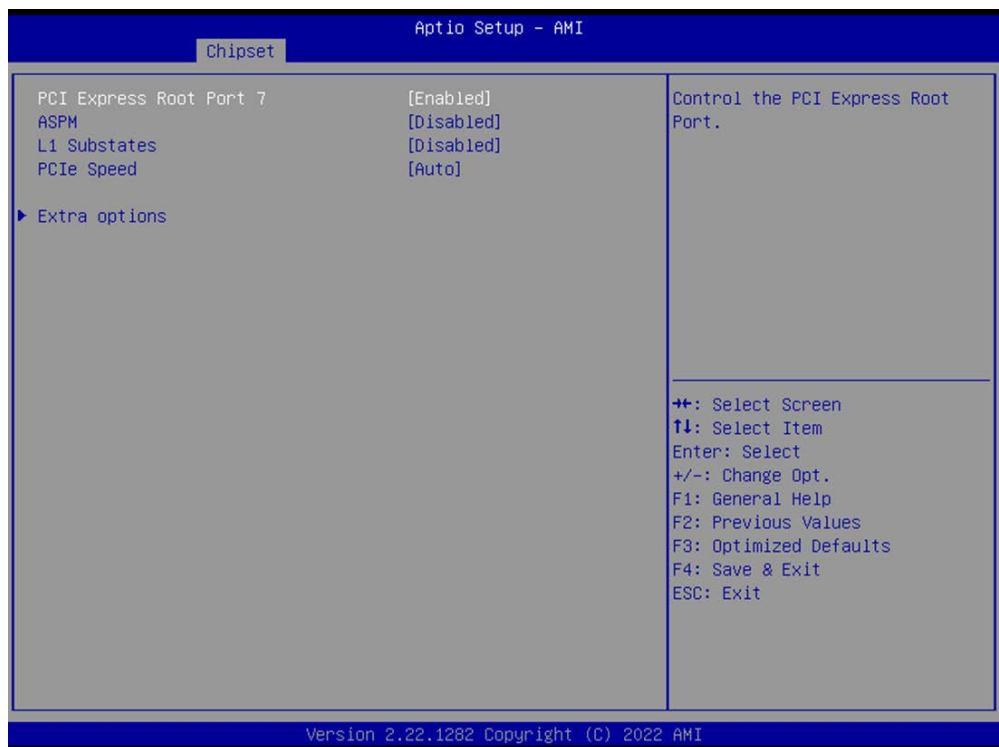
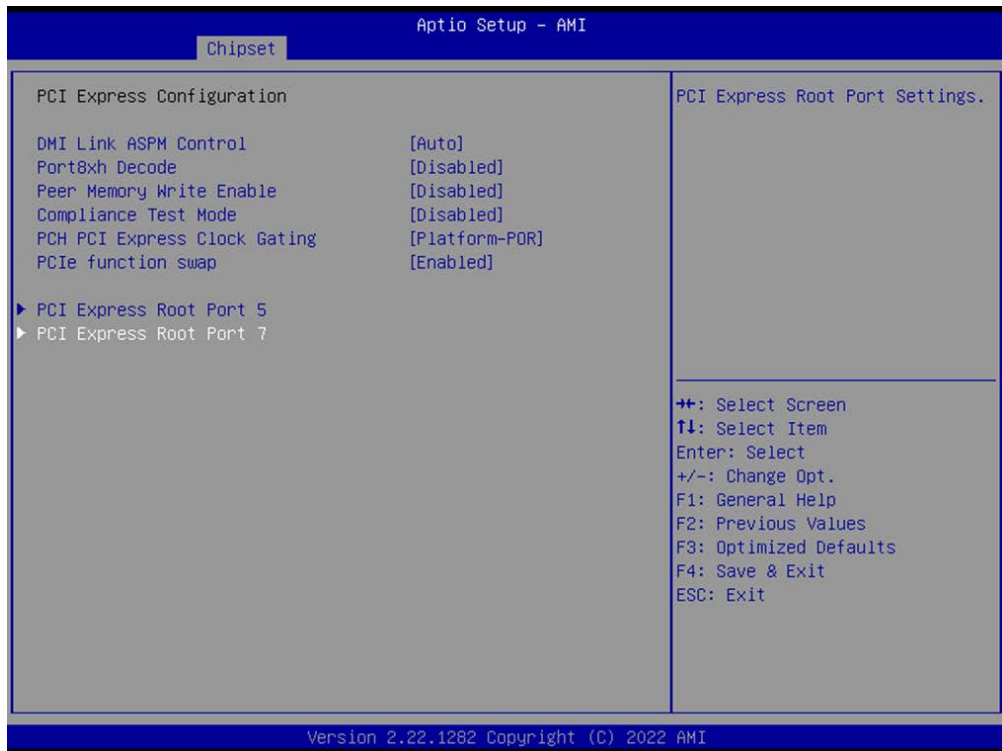

PCI Express Root Port 7

- **PCI Express Root Port 7**
- **ASPM**
- **PCIe Speed**

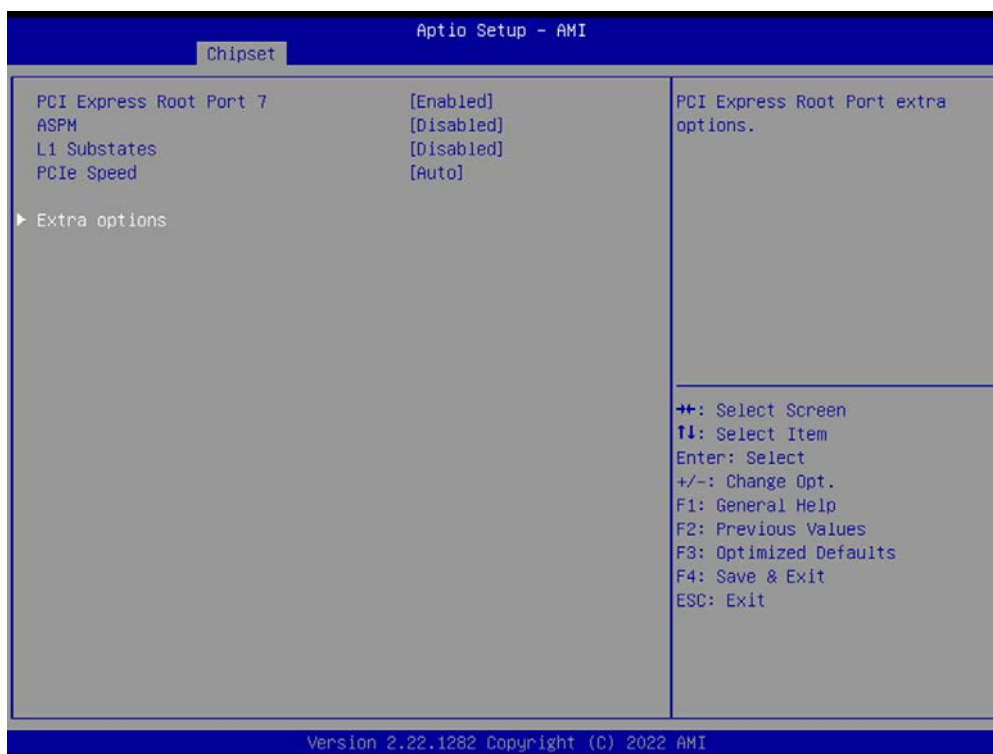

Extra Options

- **Detect Non-Compliant Device**

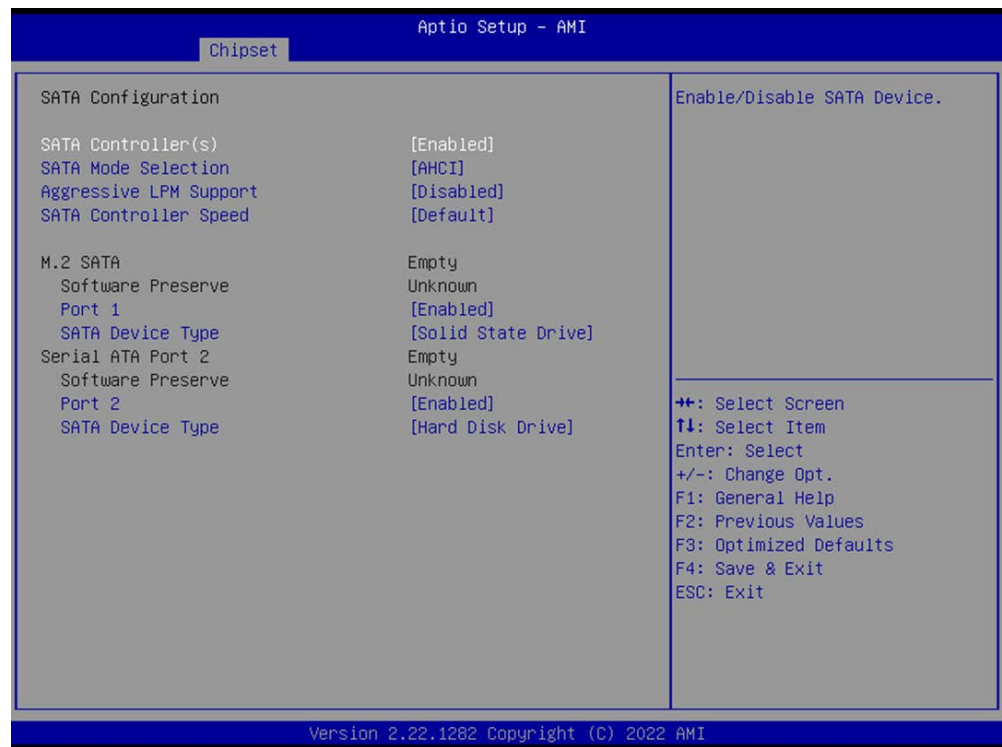
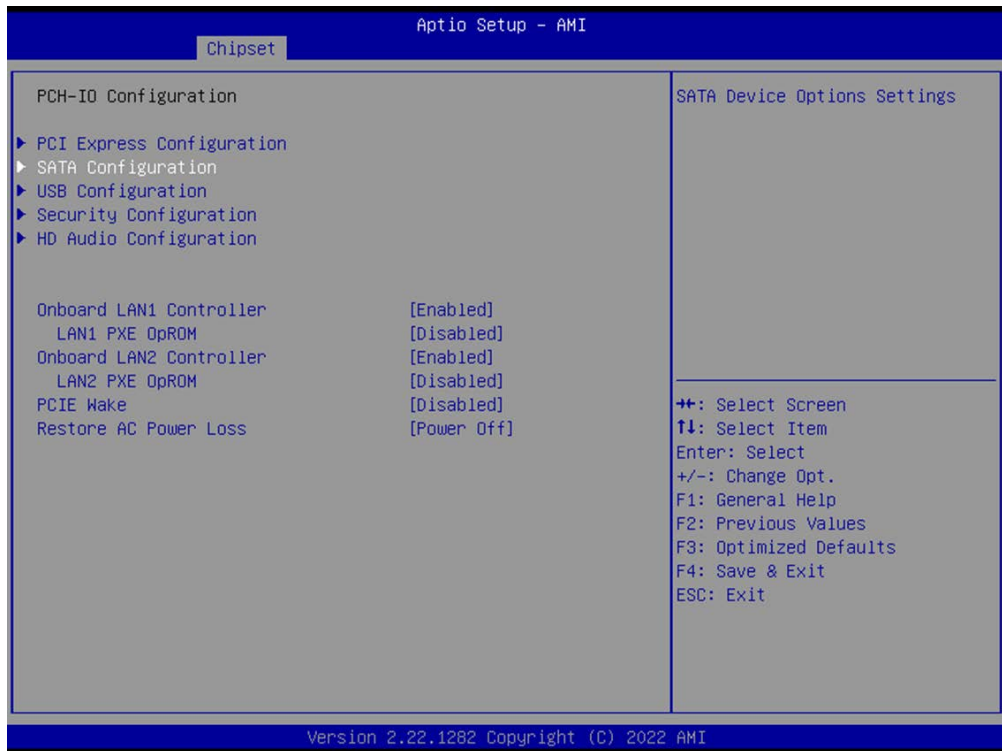

SATA Configuration

- **SATA Controller(s)**
Enable/disable SATA Device(s).
- **SATA Mode Selection**
Determine how SATA controller(s) operate.
- **Aggressive LPM Support**
Enable PCH to aggressively enter link power state.

- **SATA Controller Speed**
Indicates the maximum speed the SATA controller can support.
- **M.2 SATA**
 - Port 1: Enable or disable the SATA Port.
 - SATA Device: Identify the SATA port is connected to a Solid State Drive or Hard Disk Drive.
- **Serial ATA Port 2**
 - Port 1: Enable or disable the SATA Port.
 - SATA Device: Identify the SATA port that is connected to a Solid State Drive or Hard Disk Drive.

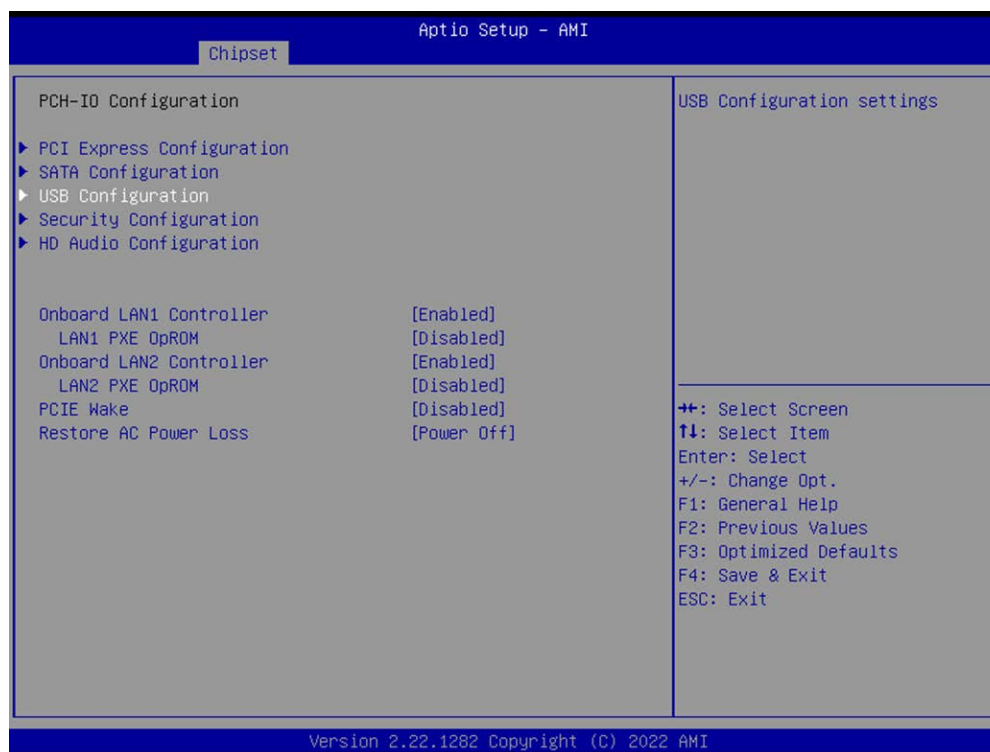

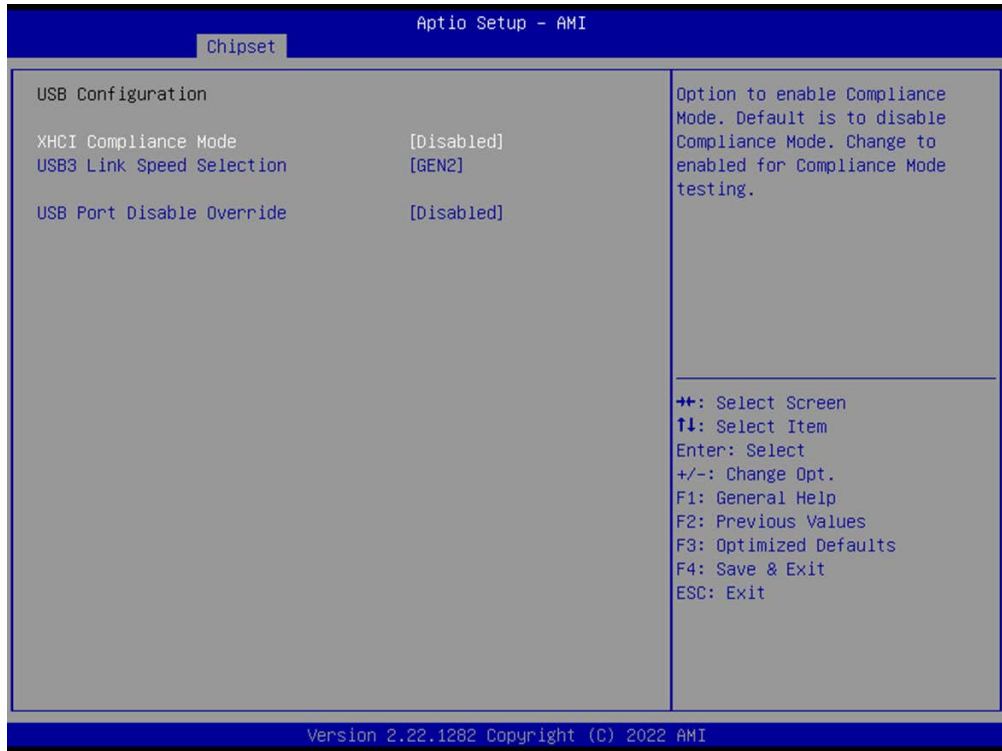

USB Configuration

- **XHCI Compliance**
Option to enable Compliance Mode.
- **USB 3 Link Speed Selection**
This option is to select USB 3 Link Speed Gen1 or Gen2.
- **USB Port Disable Override**
Selectively enable/disable the corresponding USB port from reporting a Device Connection to the controller.

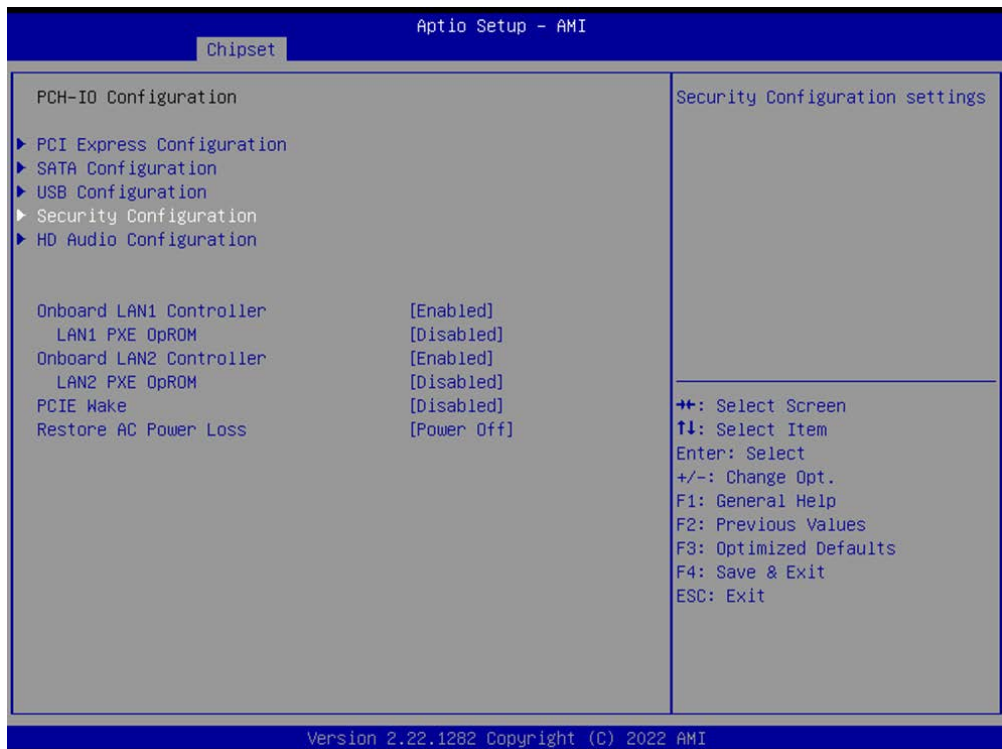



Security Configuration

- **RTC Memory Lock**
Enable will lock bytes 38h-3Fh in the lower/upper 128-byte bank of RTH RAM.
- **BIOS Lock**
Enable/disable the PCH BIOS Lock Enable feature.
- **Force unlock on all GPIO pads**
If enabled, the BIOS will force all GPIO pads to be in the unlocked state.

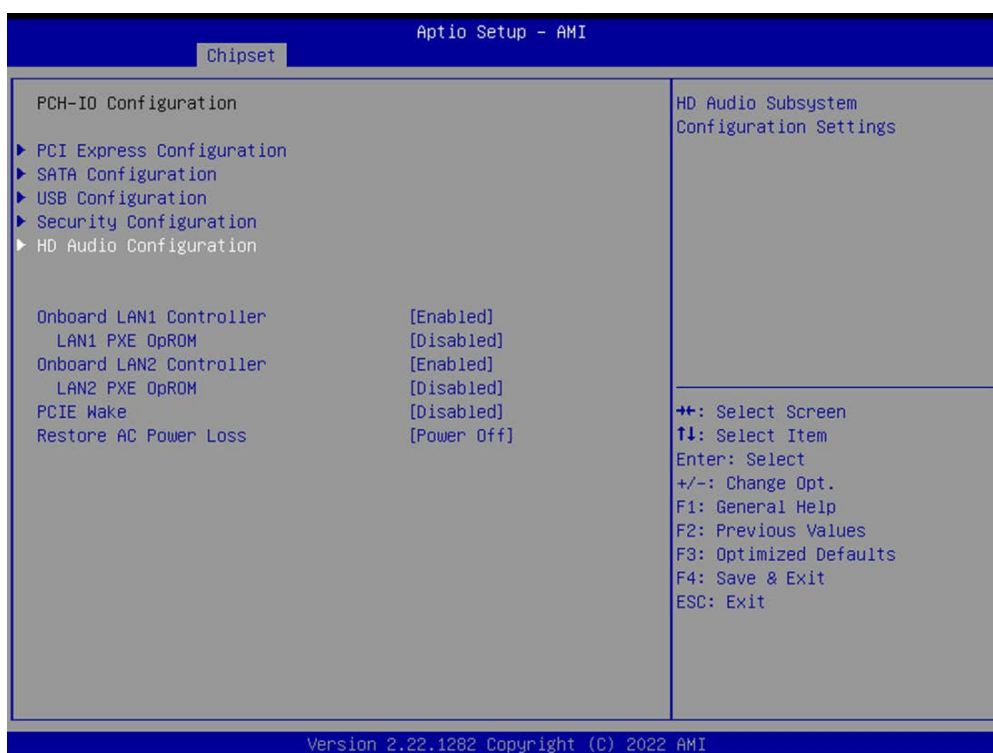

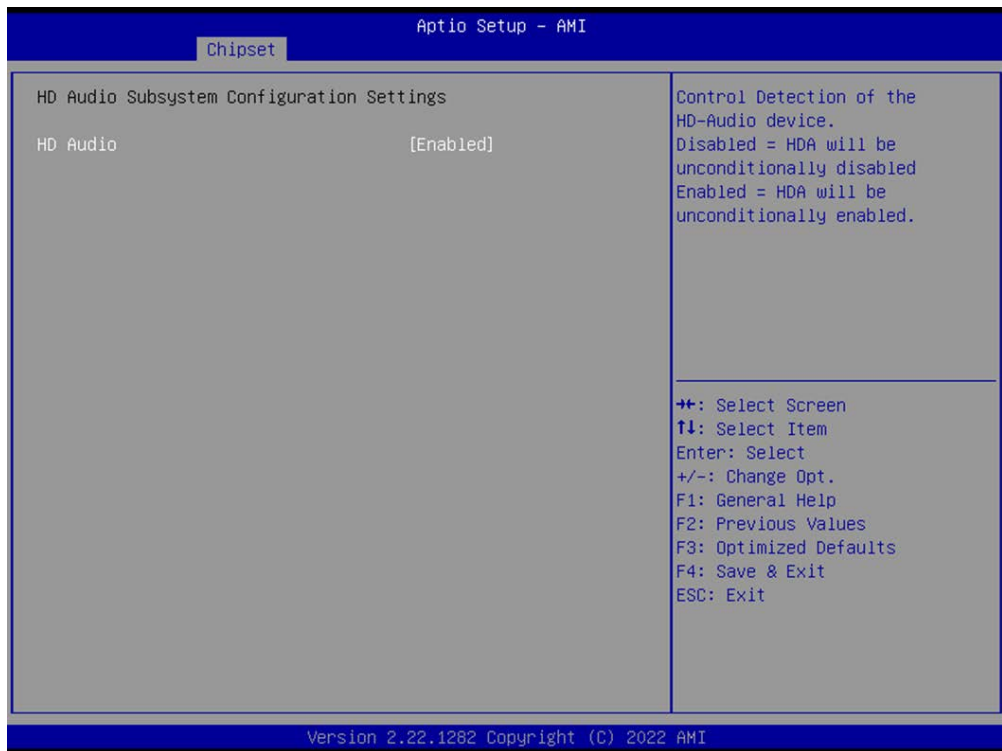

HD Audio Configuration

■ HD Audio

Control Detection of the HD-Audio device.

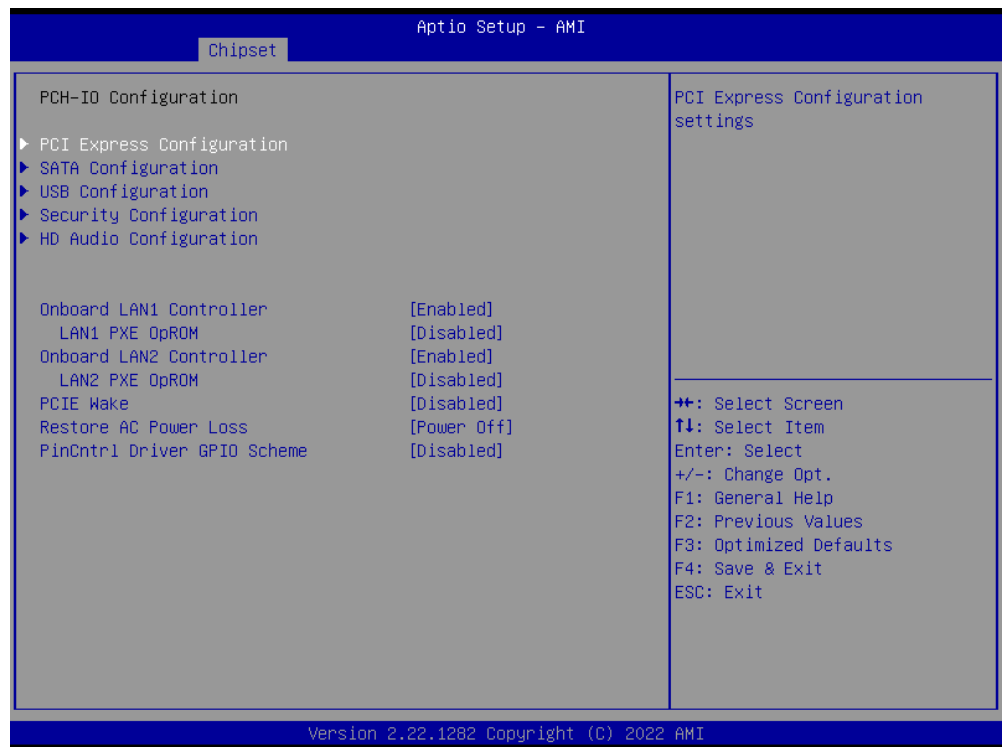

■ Onboard LAN1 Controller

Select to enable or disable the Onboard LAN1 Controller.

■ LAN1 PXE OpROM

- Enable or disable boot option for the LAN1 Controller.
- **Onboard LAN2 Controller**
Select to enable or disable the Onboard LAN1 Controller.
- **LAN2 PXE OpROM**
Enable or Disable boot option for the LAN1 Controller.
- **PinCntrl Driver GPIO Scheme**
The default is “Disabled”. Enable this option to use an OS on Linux kernel 5.10 or later.

3.2.4 Security



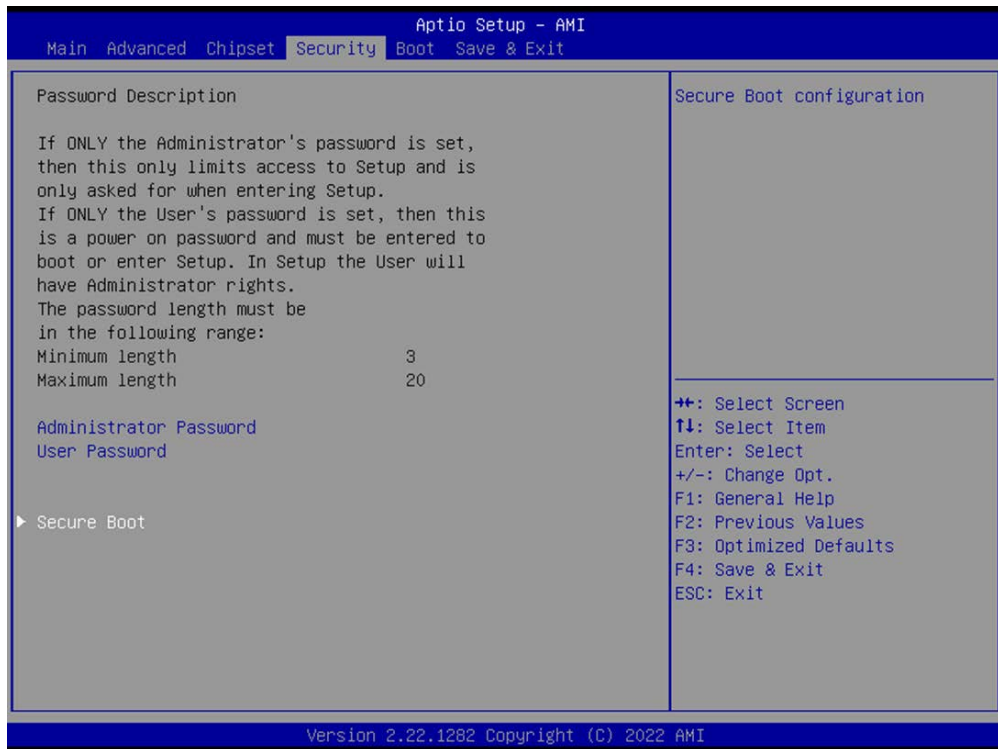

- **Administrator Password**
Set Administrator Password.
- **User Password**
Set User Password.

Secure Boot

- **Secure Boot**

The Secure Boot feature is Active if Secure Boot is Enabled, Platform Key (PK) is enrolled, and the System is in User mode. The mode change requires a platform reset.

- **Secure Boot Mode**

Secure Boot mode options: Standard or Custom. In Custom mode, Secure Boot Policy variables can be configured by a physically present user without full authentication.

- **Restore Factory Keys**

- **Key Management**

3.2.5 Boot

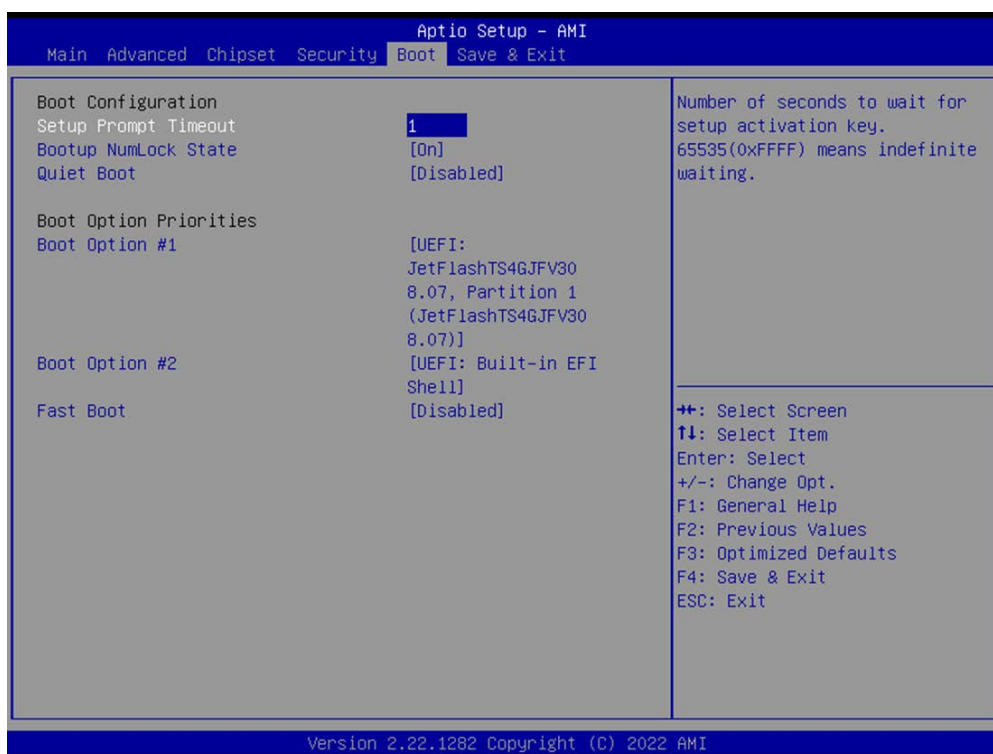

- **Setup Prompt Timeout**

Number of seconds to wait for the setup activation key.

- **Bootup NumLock State**

Select the keyboard NumLock state.

- **Quiet Boot**

Enables or disables the Quiet Boot option.

- **Boot Option #1**

Sets the system boot order.

- **Boot Option #2**

Sets the system boot order.

- **Fast Boot**

Enable or disable boot with initialization of a minimal set of devices required to launch the active boot option.

3.2.6 Save & Exit

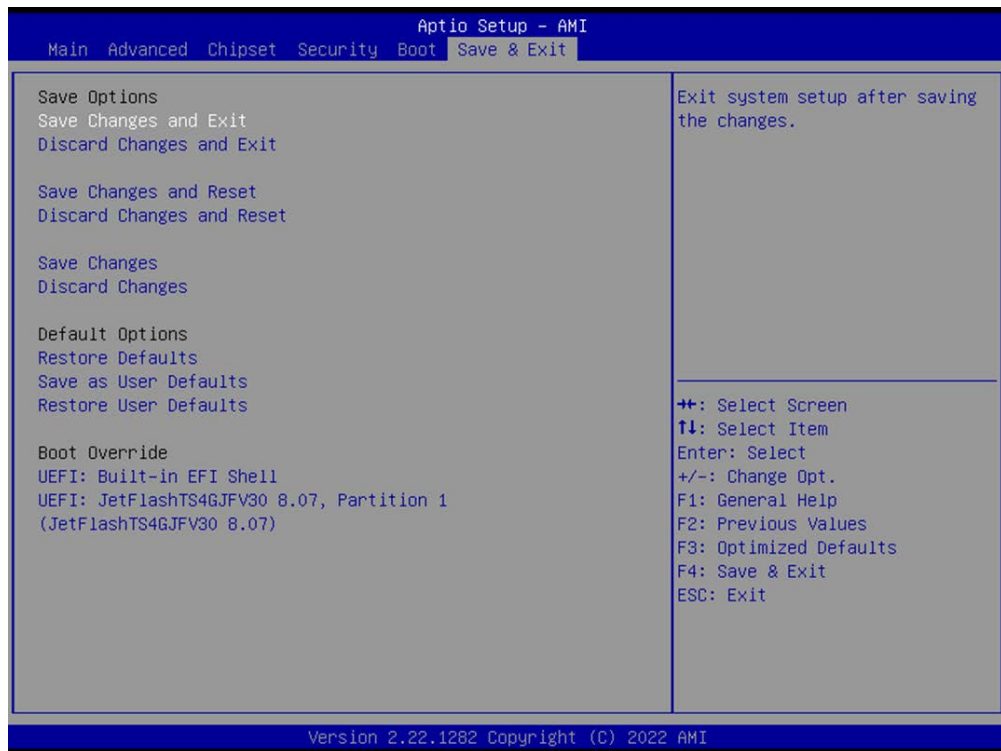

- **Changes and Exit**
Exit system setup after saving the changes.
- **Discard Changes and Exit**
Exit system setup without saving any changes.
- **Save Changes and Reset**
Reset the system after saving the changes.
- **Discard Changes and Reset**
Reset system setup without saving any changes.
- **Save Changes**
Save changes done so far to any of the setup options.
- **Discard Changes**
Discard changes done so far to any of the setup options.
- **Restore Defaults**
Restore/Load default values for all the setup options.
- **Save as User Defaults**
Save the changes done so far as User Defaults.
- **Restore User Defaults**
Restore the User Defaults to all the setup options.

ADVANTECH

Enabling an Intelligent Planet

www.advantech.com

Please verify specifications before quoting. This guide is intended for reference purposes only.

All product specifications are subject to change without notice.

No part of this publication may be reproduced in any form or by any means, electronic, photocopying, recording or otherwise, without prior written permission of the publisher.

All brand and product names are trademarks or registered trademarks of their respective companies.

© Advantech Co., Ltd. 2025