

IPPC-5211WS

21.5" Full HD TFT LED LCD Industrial Multi-Touch Panel PC Stainless Steel chassis with IP69K Rated

NEW



WebAccess/NMS SUSI Access iKey iDoor

Features

- Stainless steel chassis with IP69K waterproof rating
- The detachable product portfolio with accessories for various applications.
- Intel® Celeron Processor J1900
- Operating temperature : 0 ~ 50°C
- 21.5" Full HD TFT LED LCD display
- 16:9 widescreen with PCT multi-touch
- Supports iDoor or antenna
- Built-in function and home key button used for intuitive UI
- Fully flat glass front panel with 7H hardness
- Supports 4 GB DDR3L SO-DIMM
- Fanless cooling system
- Front LED indicator to show operating status
- Supports Advantech SNMP subagent



Introduction

The IPPC-5211WS 21.5" fully sealed stainless steel multi-touch panel PC is IP69K rated and has a detachable product portfolio designed for OEMs and process manufacturing. It supports special functions via iDoor, iKey and an antenna, and is designed for HMIs which require better performance and functionality of machine-level interfaces used in Machine-to-Machine (M2M), Internet of Things (IoT) etc which require extra protection for hygienic and harsh environments where the intrusion of dust, condensation and water jets is possible. The IPPC-5211WS can also perform a touch shut-down to avoid accidental operation.

Specifications

General

- **BIOS** AMI UEFI
- **Certification** IP69k, CE, FCC Class A, UL, CCC, BSMI
- **Cooling System** Fanless design
- **Dimensions (W x H x D)** 555 x 346.5 x 81 (21.85" x 13.64" x 3.19")
- **Enclosure** Front : Stainless steel
Back : Aluminum / stainless steel(optional)
- **Mounting** VESA and flange adapter for arm and foot system
- **Power Consumption** 40.8 W
- **Power Input** 21~27 V_{DC}
- **Weight** 15.8 Kg
- **OS Support** Windows Embedded Standard 7 (64 bit)
Windows Embedded 8 Standard (64 bit)
Windows 7 (32bit/64bit)
Windows 8 (64bit)

System Hardware

- **CPU** Intel® Celeron Processor J1900
- **Memory** 4 GB DDR3L SO-DIMM, up to 8GB
- **LAN** RTL8111E-VL-CG
- **Storage** CFast (optional)
SSD (optional)
- **I/O** 2 x 10/100/1000 Mbps RJ45
1 x RS-232 1 x RS-232/RS-485/RS-422
1 x USB 2.0 1 x USB 3.0
1 x iDoor (optional)
1 x Waterproof Wireless Antenna (optional)

LCD Display

- **Display Type** Full HD TFT LED LCD
- **Display Size** 21.5"

- **Max. Resolution** 1920 x 1080
- **Max. Colors** 16.7M
- **Luminance (cd/m²)** 300
- **Viewing Angle(H/V)** 178 / 178
- **Backlight Life** 50,000 hrs

Touchscreen

- **Light Transmission** ≥ 88%
- **Resolution** 4096 x 4096 dpi
- **Type** Projected capacitive

Environment

- **Humidity** 10 ~ 95% RH @ 40°C, non-condensing
Note: Tested for 48 hrs
- **Operating Temperature** 0 ~ 50°C (32 ~ 122°F)
- **Storage Temperature** -20 ~ 60°C (-4 ~ 140°F)

Ordering Information

- **IPPC-5211WS-J3AE** 21.5" Full HD 1080 TFT LCD with PCT touch, Intel® Celeron Processor & IP69K rating

iDoor Modules

- **PCM-24D2R4-AE** 2-Port Isolated RS-422/485 mPCIe, DB9
- **PCM-24D2R2-AE** 2-Port Isolated RS-232 mPCIe, DB9
- **PCM-27D24DI-AE** 24-Channel Isolated Digital I/O w/ counter mPCIe, DB37
- **PCM-26R2PN-MAE** 2-Port Hillscher netX100 FieldBus mPCIe, PROFINET, RJ45, Master
- **PCM-26R2PN-SAE** 2-Port Hillscher netX100 FieldBus mPCIe, PROFINET, RJ45, Slave
- **PCM-26D1DB-MAE** 1-Port Hillscher netX100 FieldBus mPCIe, PROFIBUS, DB9, Master
- **PCM-26D1DB-SAE** 1-Port Hillscher netX100 FieldBus mPCIe, PROFIBUS, DB9, Slave

Dimensions

Unit: mm [inch]

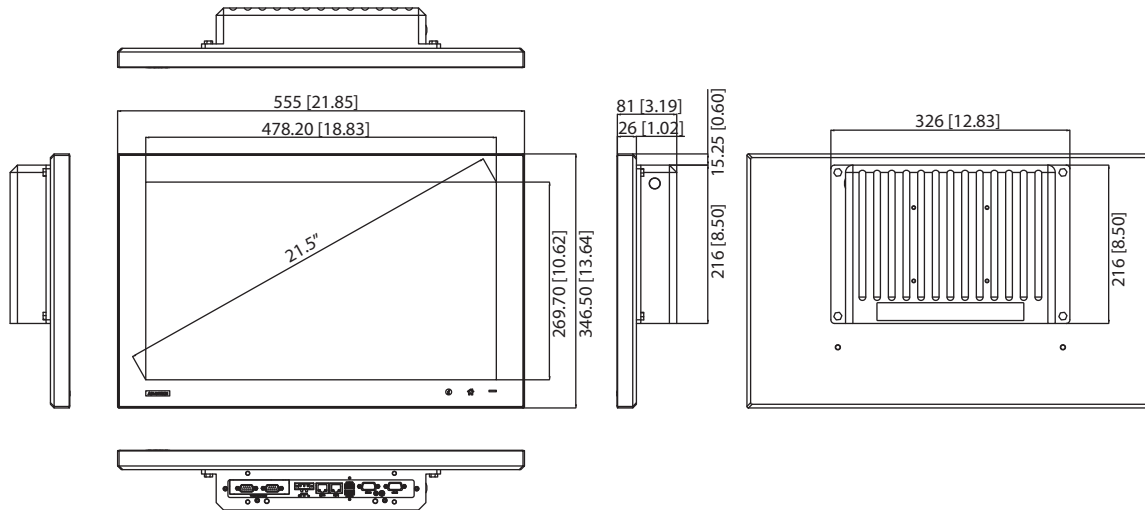

Accessories

- **IPPC-5211WS-EMKE** The flange adaptor is for connecting between the front panel and the arm or foot system.

IPPC-5211WS-EMKE

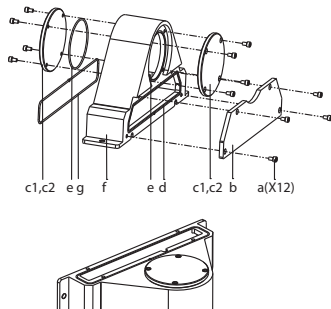

Rear View

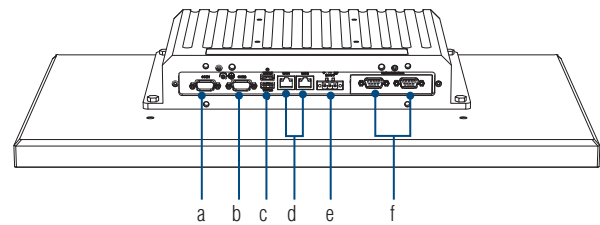

- a. COM1 (RS-232)
- b. COM2 (RS232/RS485/RS422)
- c. 2 x USB (USB3.0/ 1 x USB2.0)
- d. 2 x LAN (10/100/1000 Mbps)
- e. Power Inlet (24 V_{DC})
- f. iDoor

Optional Item List

Model	Part Number	Description
CFast	SQF-S10M2-32G-S7E	32GB, SATAII, CFast (Gen2)
CFast	SQF-S10S2-8G-S9E	8GB, SATAIII, CFast (Gen3)
CFast	SQF-S10M2-32G-S9C	32GB, SATAIII, CFast (Gen3)
SSD	SQF-S25M8-32G-S8E	SQF 2.5" SSD 820 32G MLC (-40-85°C)
SSD	SQF-S25M5-160G-S8E	SQF 2.5" SSD 820 160G MLC (-40-85°C)
Adaptor	PWR-247-BE	100-240V 63W 24V 2.62A Power Supply

Product type with IPPC-5211WS-EMKE

Arm system

Foot system

