

Stainless Panel PC

(Intel® ATOM N2600 Platform)

Stainless Flat Touch Panel PC

MODEL #: R15ID3S-65EX

Mechanical Design



Features

- This Equipment is ATEX Zone 2 certified and is suitable for use in Class I, Division 2, Hazardous area applications
- Wide power input 9-36V DC with isolation protection
- Special IP65 M12 & M21 Type connectors
- Designed with NEMA 4 (IP65) dust proof and water protection
- Robust and fanless design for reliable operation
- Fanless Cooling System and Ultra Low power consumption
- Support Intel Atom N2600 processor
- ELO 5W Resistive Touch (Explosion-proof)

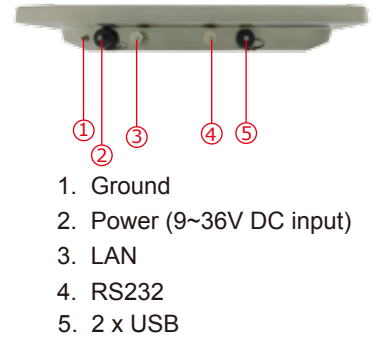
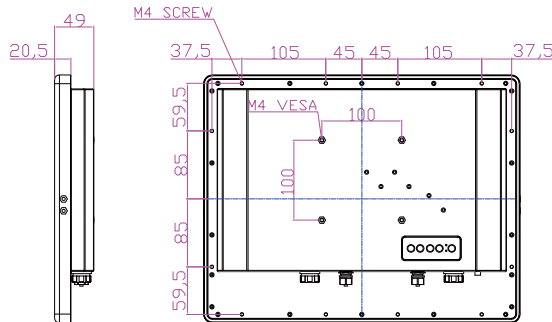
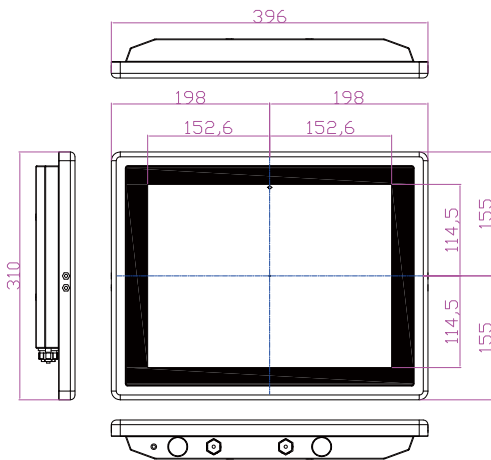

* Note: this is a simplified drawing and some components are not marked in detail. Please contact our sales representative if you need further product information.

System Specifications

TFT Characteristics :

- Resolutions : 1024 x 768
- Brightness : 550 cd/m² (typ.)
- Contrast Ratio : 700 : 1(typ.)
- Viewing Angles : -80~80(H);-70~70(V)
- Max Colors : 16.2M

Mechanical Specification :

- Cooling System : Fanless design
- Dimension(W x H x D) : 396 x 310 x 49mm

System Specifications :

- Processor : Intel® Atom N2600 1.6GHz
- BIOS : AMI BIOS
- System Chipset : Intel® NM10
- Memory Slot : 1x DDR3 SO-DIMM 1333 MHz, 4GB default
- Storage : mSATA SSD 64GB default, Option up to 128GB

Input/ Output Connectors :

- Ethernet LAN : 1 x RJ45-10/100/1000 Mbps
- COM : 1 x RS232(Optional RS422/RS485)
- USB : 2 x USB Type-A Receptacle
- Power : 1 x 9-36VDC

Order Information (optional)

- Memory : SO DIMM DDR3 2GB / 4GB
- Storage : 32GB / 64GB / 128GB mSATA SSD
- OS : Windows Embedded Standard 7
Windows 7 Pro for Embedded Systems

Power Specifications :

- Power Input : 9-36V DC in
- Power Consumption : 25W (typ.)(Max.backlight & high CPU load)

Standards and Certifications

- Safety : UL60950-1, CSA C22.2 No. 60950-1-07, EN60950-1, IEC60950-1
- Hazardous Location : ATEX zone 2
EX II 3 G Ex ic nA IIC Gc
UL Class I, Div.2, Groups ABCD T4
ANSI/ISA12.12.01
CAN/CSA C22.2 No. 213-M1987
- Hazardous Location Operating Temp. : -20°C ~ 50°C (Tamb)
- Operating Humidity : 10% to 95% (non condensing)
- Shock : MIL-STD-810G Method 516.6
- Vibration : MIL-STD-810G Method 514.6
- Transit Drop : MIL-STD-810G Method 516.6
- CE
- FCC
- CSA
- UL60950-1

Accessories :

- 1 x M21 to DC power cable with Power Adapter / Power cord
- 1 x M12 to RJ45 cable
- 1 x M12 to RS232 cable
- 1 x M21 to 2 x USB cable
- 1 x M21 to DC power Cable open wire

Stainless Panel PC

(Intel® ATOM N2600 Platform)

Stainless Flat Touch Panel PC

MODEL #: R15ID3S-65EX

Accessories Cables Pin assignments

USB cable

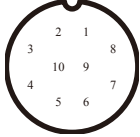
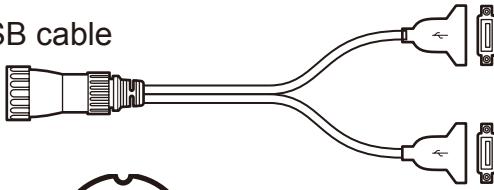

Pin No.	Symbols	Color
CN1-1	VCC	RED
CN1-2	VCC	RED
CN1-3	D-	WHITE
CN1-4	D-	WHITE
CN1-5	D+	GREEN
CN1-6	D+	GREEN
CN1-7	GND	BLACK
CN1-8	GND	BLACK
CN1-9	Braid	

Ethernet (LAN) cable

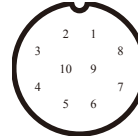

Pin No.	Color
CN2-1	White/Orange
CN2-2	Orange
CN2-3	White/Green
CN2-4	Blue
CN2-5	White/Blue
CN2-6	Green
CN2-7	White/Brown
CN2-8	Brown

Power adapter

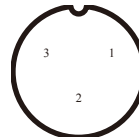
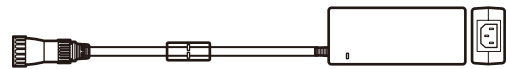

Pin No.	Symbols	Color
CN2-1	VCC	Follow Adapter
CN2-2	GND	Follow Adapter
CN2-3	GND	Follow Adapter

RS-232 cable

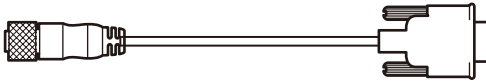

Pin No.	Symbols	Color
CN2-1	DCD-CON2	Green
CN2-2	DSR-CON2	Brown
CN2-3	RXD-CON2	Red
CN2-4	RTS-CON2	Orange
CN2-5	TXD-CON2	Blue
CN2-6	CTS-CON2	White
CN2-7	DTR-CON2	Purple
CN2-8	RI-CON2	Yellow
CN2-9	GND-CON2	Black

DC power cable open wire

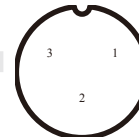

Pin No.	Symbols	Color
CN2-1	VCC	Red
CN2-2	Shield	
CN2-3	GND	Black

WARNING

Ensure that the external power source is OFF before connecting or disconnecting the DC in jack.

Mounting Instruction

Customer's Cutout

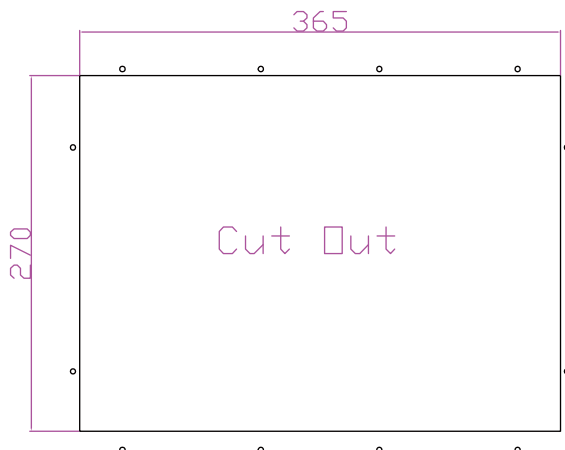

Mount the Unit to the Enclosure

