

R20L100-RKA2ML

20.1" Rack Mount Protective Glass Defence Display



KEY FEATURES

- Compliant MIL-STD 810G/ MIL-STD 461E Rack Mount Protective Glass Defence Display
- Rack mount mechanical design, supports VESA mount
- High image quality, 1600 x 1200 pixels resolution
- AR protection glass
- Defence-grade power connector (MIL-DTL-38999/1)
- AC 100~240V, Universal, $\pm 10\%$; DC 9~36V, $\pm 10\%$ (Optional)
- Resistive Touch (Optional)
- Build-in Light Sensor for Auto Brightness Control



SPECIFICATIONS

Display			
Resolution	1600x1200	Size	20.1 inches
Contrast Ratio	1400:1	Panel Brightness	330.0 nits
Display Color	16.7M Colors	View Angles	85,85,85,85
Active Area	408x306 mm	Touch / Glass	Protection Glass
Environment			
Operating Humidity	10% to 95% RH	Operating Temperature	0~50°C
Storage Temperature	-10°C~60°C		
Compliance			
MIL-STD 461E/F/G	RE101 / RE102 CE101 / CE102 CS118 with EMI Glass / Touch(Optional) RS101 / RS 103 CS101 / CS 106 / CS 109 / CS 114 / CS 115 / CS 116	MIL-STD 810G/H	Vibration Method 514.6 Humidity Method 507.5 Transit Drop Method516.6
Certification			
Certification	CE, FCC		
IO Ports			
Video	1 x 15 Pin D-Sub 5 x BNC 1 x DVI-D		
Mechanical			
Dimension	482.6 x 399.3 x 80 mm	Mounting	Rack Mount/ VESA Mount
Enclosure	Metal Housing with Aluminum Bezel	Cooling System	Fanless Design
Power			
Power Rating	AC 100~240V, Universal, $\pm 10\%$ DC 9~36V, $\pm 10\%$ (Optional)		
Accessory			

Accessory	1 x User Manual(Hardcopy) 1 x Power Cord MIL-DTL-38999/1 1 x VGA Cable 1 x DVI Cable 1 x VGA to 5 BNC Shielding Cable
------------------	---

Control

Button	8 key: Power Menu Auto Volume Up/ Swap Volume Down/ PIP Brightness Up Brightness Down LED Adjustment
---------------	--

DIMENSIONS UNIT:MM

Winmate 20.1" Rack Mount Defence Display R20L100-RKA2ML

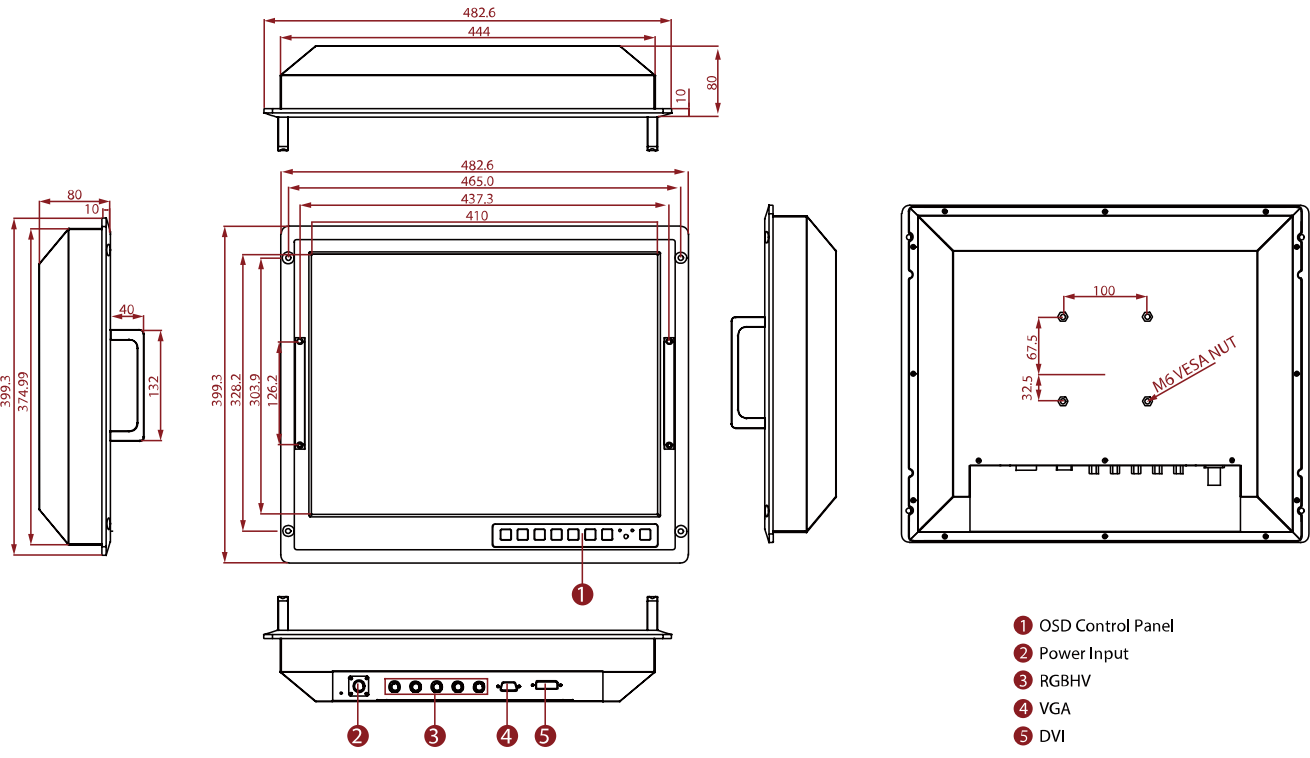

NOTE

1. This is a simplified drawing and some components are not marked in detail.
2. If you require an external test report, Winmate will charge an NRE fee.
3. Please contact our sales representative if you need further product information.
4. All specifications are subject to change without prior notice.
5. The product shown in this datasheet is a standard model. For diagrams that contain customized or optional I/O, please contact the Winmate Sales Team for more information.