

# TPC-650H TPC-1250H TPC-1550H TPC-1750H

## 5.7" VGA/12.1" SVGA/15" XGA/17" SXGA TFT LED LCD Intel® Atom™ Thin Client Terminals



### Features

- Intel® Atom™ N270 1.6 GHz processor
- 5.7" VGA/12.1" SVGA/15" XGA/17" SXGA TFT LED LCD
- Fanless cooling system
- IP65 compliant front panel
- Supports Microsoft® Windows XP/XPe/CE
- Windows CE 5.0/6.0 with Java Script ready
- Supports Linux OS with Firefox and Java Script plugins
- Gigabit Ethernet supported
- Energy Star approved
- Supports external 2.5" SATA HDD kit

### Introduction

With a high quality TPC product line, TPC extends its Touch Panel Computer family with Intel® Atom™ platform for 5.7", 12.1", 15" and 17". TPC thin client is designed with Intel® Atom™ 1.6 GHz processor as its core. The Intel® Atom™ has low power consumption and 1.6 GHz operating frequency. This system is fanless, slim design for Web-based terminal solutions, so JavaScript is included in the Windows operating system. For Linux systems, we provide Mozilla Firefox.

### Specifications

#### General

- BIOS** Award® 4Mbit
- Certification** BSMI, CCC, CE, FCC Class A, UL
- Cooling System** Fanless design
- Dimensions (W x H x D)** 650H: 195 x 148 x 58 mm (7.68" x 5.83" x 2.28")  
1250H: 311 x 237 x 54 mm (12.24" x 9.33" x 2.12")  
1550H: 383 x 307 x 58.1 mm (15.08" x 12.09" x 2.29")  
1750H: 413.7 x 347.2 x 63.8 (16.28" x 13.68" x 2.5")
- Enclosure** TPC-650H Front bezel: PC/ABS Resin  
TPC-1250H/1550H/1750H front bezel: Die-cast aluminum alloy  
Back housing: SECC
- Mounting** Desktop, Wall (only for TPC-1250H/1550H/1750H) or Panel Mount
- OS Support** Microsoft® Windows® 7/XPE/WES  
Windows CE 5.0/6.0 with Java Script  
Linux with Firefox explorer and Java Script plugin
- Power Consumption** 17 W/35 W/40 W/43W (typical)
- Power Input** 18 ~ 28 V<sub>DC</sub>, 18 ~ 32 V<sub>DC</sub> (TPC-1750H only)
- Watchdog Timer** 1 ~ 255 sec (system)
- Weight (Net)** 1.43 kg (3.15 lb)/2.5 kg (5.51 lb)/3 kg (6.61 lb)/3.5 kg (7.71 lb)

#### System Hardware

- CPU** Intel® Atom™ N270 1.6 GHz
- Chipset** Intel® 945GSE+ICH7M
- Memory** 2GB SO-DIMM DDR2 667 SDRAM  
1GB SO-DIMM DDR2 667 SDRAM (TPC-650H only)
- LAN** 10/100/1000Base-T x 2, (TPC-650H with One Giga LAN)
- Storage** CFast slot x 1  
CompactFlash slot x 1 (TPC-650H only)  
Optional, external 2.5" SATA HDD kit (TPC-1250H/1550H/1750H only)

- I/O** TPC-650H: RS-232 x 2 (COM1, 2)  
TPC-1250H/1550H/1750H: RS-232 x1, RS-232/422/485 x 1  
USB 2.0 x 2 (Host)  
PS/2 x 1 (TPC-650H only)

#### LCD Display

- Display Type** VGA/SVGA/XGA/SXGA TFT LED LCD
- Display Size** 5.7"/12.1"/15"/17"
- Max. Resolution** 640 x 480/800 x 600/1024 x 768/1280 x 1024
- Max. Colors** 262 K
- Luminance cd/m<sup>2</sup>** 700/450/350/350
- Viewing Angle (H/V°)** 160/140; 170/160 (TPC-1750H only)
- Backlight Life** 50,000 hrs
- Contrast Ratio** 800:1/700:1/700:1/1000:1

#### Touchscreen

- Lifespan** 10 million touches at single point
- Light Transmission** Above 75%
- Resolution** Linearity
- Type** 5-wire, analog resistive

#### Environment

- Humidity** 10 ~ 95% RH @ 40°C, non-condensing
- Ingress Protection** Front panel: IP65
- Operating Temperature** 0 ~ 45°C (32 ~ 113°F)
- Storage Temperature** -20 ~ 60°C (-4 ~ 140°F)
- Vibration Protection** 2 Grms (5 ~ 500 Hz) (Operating, random vibration)

# TPC-650H/1250H/1550H/1750H

## Dimensions

### TPC-650H

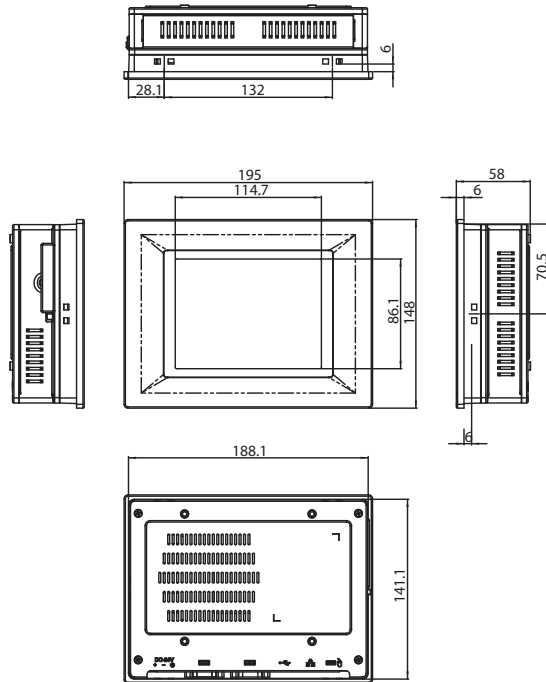

### TPC-1250H/1550H/1750H

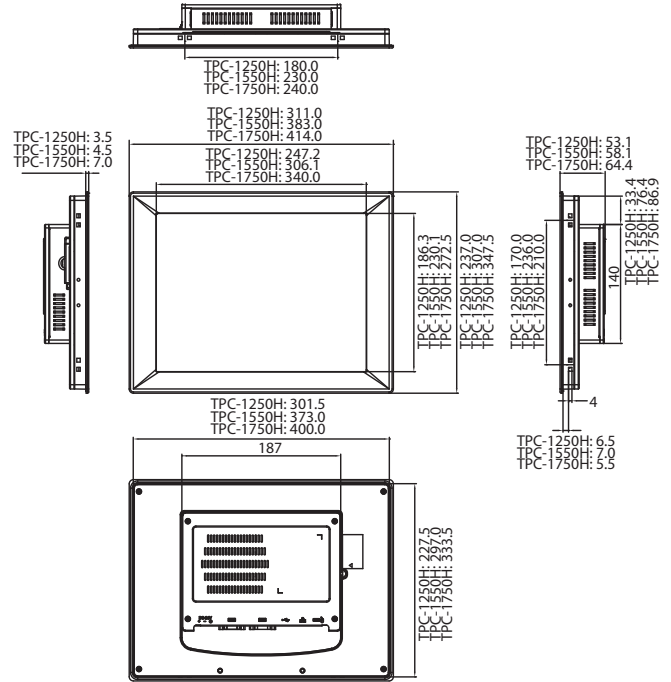

Unit: mm

**Panel Cut-out Dimensions:**  
 TPC-650H: 189.1 x 142.1 mm (7.56" x 5.68")  
 TPC-1250H: 302.5 x 228.5 mm (12.1" x 9.14")  
 TPC-1550H: 374.5 x 298.5 mm (14.98" x 11.94")  
 TPC-1750H: 400.8 x 334.3 mm (16.03" x 13.37")

## Ordering Information

- **TPC-650H-N2AE** 5.7" VGA Touch Panel PC, Atom™ N270 1.6GHz, 1GB
- **TPC-1250H-N2BE** 12.1" SVGA Touch Panel PC, Atom™ N270 1.6GHz, 2GB
- **TPC-1550H-N2BE** 15" XGA Touch Panel PC, Atom™ N270 1.6GHz, 2GB
- **TPC-1750H-N2BE** 17" SXGA, Touch Panel PC, Atom™ N270 1.6GHz, 2GB

## Accessories

- **TPC-1000H-WMKE** TPC series wallmount kit from 10" to 17"
- **TPC-1000H-SMKE** TPC series stand kit from 10" to 17"
- **TPC-651H-EHKE** TPC-x50H/x51H series Extension HDD Kit

\* VESA support via a wall mounting kit (only for TPC-1250H/1550H/1750H)

## Rear View

### TPC-1250H/1550H/1750H

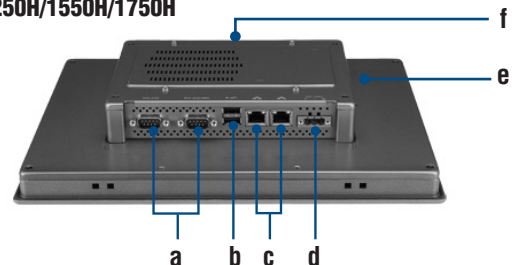

### TPC-650H

